

Proceedings of the
**2013 Nova Scotia Tidal Energy
Research Symposium & Forum**

14-15 May 2013
Acadia University
Wolfville, Nova Scotia, Canada

Editors:

Lisa Isaacman & Anna M Redden

Steering Committee:

Anna Redden, Acadia Tidal Energy Institute, Acadia University
Wanda Barrett & Nalani Perry, Offshore Energy Research Association
Sandra Farwell, Mana Wareham & Alan Howell, NS Department of Energy
Lisa Isaacman (Symposium Coordinator), Fundy Energy Research Network

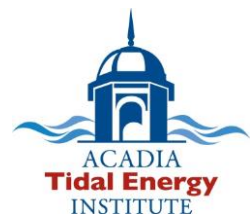

Proceedings of the 2013 Nova Scotia Tidal Energy Research Symposium & Forum

14-15 May 2013
Acadia University
Wolfville, Nova Scotia, Canada

Editors:

Lisa Isaacman

Fundy Energy Research Network
Wolfville, Nova Scotia, Canada B4P 2R6

Anna M. Redden

Acadia Tidal Energy Institute
Acadia University
Wolfville, Nova Scotia, Canada B4P 2R6

Recommended Citation:

Isaacman, L. and A.M. Redden (eds.). 2013. Proceedings of the 2013 Nova Scotia Tidal Energy Research Symposium and Forum. 14-15 May 2013, Acadia University, Wolfville, Nova Scotia, Canada. Report of the Nova Scotia Tidal Energy Research Symposium and Forum Steering Committee.

ISBN: 978-0-9920762-0-7

Proceedings available at <http://fern.acadiau.ca> and <http://www.oera.ca>

SPONSORS AND FUNDING PARTNERS



TABLE OF CONTENTS

1.0	INTRODUCTION.....	4
2.0	SYMPOSIUM & FORUM ORGANIZERS.....	5
3.0	COMMONLY-USED ACRONYMS AND ABBREVIATIONS.....	6
4.0	SYMPOSIUM & FORUM PROGRAMME.....	7
5.0	TECHNICAL PRESENTATION ABSTRACTS.....	12
	MARINE RENEWABLE ENERGY POTENTIAL IN COASTAL CAPE BRETON AND THE BRAS D'OR LAKES ...	12
	THE COMMUNITY AND BUSINESS TIDAL ENERGY TOOLKIT: SUPPORTING TIDAL ENERGY DEVELOPMENT IN NOVA SCOTIA.....	13
	TURBULENCE MEASUREMENT IN HIGH SPEED TIDAL CHANNELS: RESULTS FROM AN INITIAL EXPERIMENT, AND FUTURE DIRECTIONS.....	14
	CROSS-COUPLING BETWEEN DEVICE-LEVEL CFD AND OCEANOGRAPHIC MODELS APPLIED TO TISECS IN MINAS PASSAGE AND PETIT PASSAGE.....	15
	MAPPING THE BAY OF FUNDY.....	18
	SEASONAL CHANGE IN GRAIN SIZE AND ERODIBILITY ON A TIDAL CHANNEL-FLAT COMPLEX IN KINGSPORT, N.S.....	19
	SOCIAL STUDIES RESEARCH IN MARINE RENEWABLE ENERGY: RESEARCH PRIORITIES IDENTIFIED BY THE INTERNATIONAL NETWORK FOR SOCIAL STUDIES OF MARINE ENERGY (ISSMER).....	20
	GETTING PLUGGED IN: ASSESSMENT OF CABLE LAY OPERATIONS FOR TIDAL ENERGY DEVELOPMENTS IN THE MINAS PASSAGE.....	23
	MEASUREMENT OF LONG-TERM AMBIENT NOISE AND TIDAL TURBINE LEVELS IN THE BAY OF FUNDY.....	26
	SEDIMENT-LADEN ICE: IS IT A SERIOUS IMPEDIMENT TO SUBSURFACE TIDAL TURBINES IN MINAS PASSAGE?.....	27
	CRITERIA FOR SITE SELECTION OF TIDAL POWER IN STREAM DEVICES: THE IMPORTANCE OF THE GEOLOGICAL ENVIRONMENT.....	28
	INTERTIDAL SEDIMENT DYNAMICS: CHALLENGES, LESSONS LEARNED AND POTENTIAL IMPACTS OF TIDAL POWER DEVELOPMENT.....	29
	DEVELOPMENT OF TEMPORAL MONITORING TECHNIQUES FOR BENTHIC HABITAT IMPACTS OF TIDAL ENERGY.....	30
	ASSESSMENT OF ZOOPLANKTON INJURY AND MORTALITY RESULTING FROM THE DEPLOYMENT OF UNDERWATER TURBINES FOR TIDAL ENERGY PRODUCTION.....	31
	USE OF HYDROACOUSTIC TELEMETRY TO DETECT MOVEMENTS OF MIGRATORY FISHES AND LOBSTERS IN THE MINAS PASSAGE.....	32

PASSIVE ACOUSTIC MONITORING OF HARBOUR PORPOISE AT THE FORCE SITE IN MINAS PASSAGE.....	33
6.0 RESEARCH POSTER PRESENTATION ABSTRACTS.....	34
GEOMETRY AND COMPOSITION OF ICE BANKS IN A MACROTIDAL CHANNEL	34
SEASONAL CONTROL OF BIOFILMS ON SEDIMENT EROSION FROM AN INTERTIDAL MUD FLAT IN KINGSPORT, NS.....	35
MODELING THE IMPACT OF LARGE-SCALE TIDAL POWER ON SEDIMENT TEXTURE IN THE BAY OF FUNDY	36
RIDING THE TIDE IS NO BORE: TEMPORAL AND SPATIAL MOVEMENT PATTERNS OF STRIPED BASS IN THE MINAS PASSAGE, BAY OF FUNDY	37
ELECTRICAL DESIGN CONSIDERATIONS OF SUBMARINE POWER CABLES.....	38
ACOUSTIC DETECTION RANGES FOR MARINE MAMMAL MONITORING AT A TIDAL TURBINE SITE: GRAND PASSAGE, NS.....	46
MEASUREMENTS AND SIMULATIONS OF THE FLOW IN DIGBY NECK PASSAGES.....	47
SEASONAL MIGRATION OF THE AMERICAN LOBSTER, <i>HOMARUS AMERICANUS</i> , THROUGH THE FORCE TIDAL TURBINE TEST SITE AND MINAS PASSAGE, BAY OF FUNDY	48
BOTTOM SUBSTRATE AND ASSOCIATED EPIFAUNA AT THE FORCE TIDAL TURBINE TEST SITE, MINAS PASSAGE, BAY OF FUNDY	49
HIGH RESOLUTION NUMERICAL MODELLING OF DIGBY NECK PASSAGES	50
THE COMMOTION IN THE OCEAN – DETECTING HARBOUR PORPOISES (<i>PHOCOENA PHOCOENA</i>) AT THE FORCE TURBINE TEST SITE IN THE MINAS PASSAGE, BAY OF FUNDY.....	51
SEASONAL SEDIMENTATION AND HYDRODYNAMICS IN A BAY OF FUNDY TIDAL CREEK AND SALT MARSH SYSTEM	52
INTRODUCING A DYNAMIC PENETROMETER FOR GEOTECHNICAL TIDAL ENERGY CONVERTER SITE ASSESSMENT AND MONITORING.....	53
OBSERVATIONS OF HARBOUR PORPOISE (<i>PHOCOENA PHOCOENA</i>) AT THE FUNDY TIDAL ENERGY DEMONSTRATION SITE, MINAS PASSAGE, NOVA SCOTIA, 2009-2012	54
FUNDY TIDAL ENERGY DEMONSTRATION SITE, SEABIRD SURVEYS—MINAS PASSAGE, 2008-2012.....	55
SEASONAL VARIABILITY OF TOTAL SUSPENDED MATTER IN MINAS BASIN, BAY OF FUNDY	56
ON THE MELT RATE OF SUBMERGED SEDIMENT-LADEN ICE.....	57
THE LEVELIZED COST OF ENERGY AND THE IMPORTANCE OF CASH FLOW RISK ANALYSIS	58
7.0 SUMMARIES OF BREAKOUT SESSION DISCUSSIONS.....	59
DAY 1 BREAKOUT SESSION THEME: COLLABORATION AND ENGAGEMENT IN TIDAL ENERGY RESEARCH & DEVELOPMENT.....	59
Group 1 – International Opportunities.....	59
Group 2 – Research Collaboration across Tidal Sites in Nova Scotia (Minas Passage, Digby Neck, Cape Breton).....	60
Group 3 – Regional Multi-Sector Collaboration (Academic, Government, Industry).....	61
Group 4 – Involvement of Community Stakeholders, Policy Makers and Regulators.....	63
Group 5 – Coordination of Roles and Responsibilities among Groups and Institutions.....	65

Group 6 – Engagement and Collaboration with Students in Tidal Energy Research in Nova Scotia.....	67
DAY 2 BREAKOUT SESSION THEME - SOLUTIONS TO RESEARCH CHALLENGES	70
Group 1 - Technical Challenges to Environmental Sensing and Monitoring in High Flow Environments.....	71
Group 2 - Turbine and Infrastructure Engineering, Operation and Maintenance Challenges in High Flow Sites	72
Group 3 - Environmental Research and Monitoring to Minimize Risk and Uncertainty: a) cumulative and scale-specific environmental effects and b) activities beyond the scope of regulatory requirements	73
Group 4 - Determining the Potential Social and Economic Outlook of In-Stream Tidal Energy in Nova Scotia.....	74
Group 5 - Access to Existing Technical Data & Information Sharing Among Teams, Institutions and Sectors.....	75
 8.0 LIST OF SYMPOSIUM DELEGATES	 77

1.0 INTRODUCTION

The Nova Scotia Tidal Energy Research Symposium and Forum was held on 14-15 May 2013 at the KC Irving Environmental Science Centre, Acadia University, Wolfville, NS. The purpose was to provide a forum for individuals engaged in ongoing and recently completed environmental, technological / engineering and socioeconomic research and technical work related to tidal energy development in Nova Scotia to share and discuss their activities, findings and insights.

Over 100 people from Nova Scotia, New Brunswick, British Columbia, Washington, and Massachusetts attended the 2 day event, with delegates representing academia, government, and public and private sector organizations involved in tidal energy research.



OERA Executive Director, Stephen Dempsey, presenting to the delegates of the NS Tidal Energy Research Symposium and Forum, 14-15 May 2013. Photo Credit: Monica Reed.

The symposium and forum included:

- Updates on Marine Renewable Energy developments and related activities in Nova Scotia;
- Overviews of recently funded research projects and associated technical needs;
- Oral and poster presentations on results and lessons learned from ongoing and recently completed research and technical work related to tidal energy development in Nova Scotia and its practical relevance to development and regulation;

- Focused break-out sessions with facilitated discussions on
 - collaboration and engagement in tidal energy R&D
 - information/technology gaps and challenges
 - technological solutions to address tidal energy development challenges;
- A panel session featuring tidal energy Research and Development (R&D) financing, including Feed-in-Tariffs and regional and national priorities and opportunities;
- Networking opportunities to foster dialogue, understanding and cooperation among the research community, industry and regulators.

The following sections include information on the symposium organisers, the 2-day programme of events, abstracts (and some extended abstracts) of all oral and poster research presentations, summaries of the facilitated break-out sessions and a list of the Tidal Energy Research Symposium and Forum delegates.

2.0 SYMPOSIUM & FORUM ORGANIZERS

Steering Committee:

Anna Redden, Acadia Tidal Energy Institute, Acadia University

Wanda Barrett & Nalani Perry, Offshore Energy Research Association of Nova Scotia

Sandra Farwell, Mana Wareham & Alan Howell, Nova Scotia Department of Energy

Lisa Isaacman (Symposium Coordinator), Fundy Energy Research Network

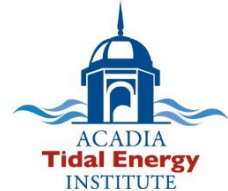

Symposium Facilitator: Graham Daborn, Acadia University

Special thanks to:

Breakout group leads: Dan MacDonald, Alex Hay, Elisa Obermann, John Colton, Carey Ryan, Justine McMillan, Monica Reed, Simon Melrose, Sue Molloy, Kristian Curran, Kay Crinean and Richard Karsten

Monica Reed, Jeremy, Broome, and Kaycee Morrison for assistance with preparing delegate packages, venue set-up, take-down and registration

Leanna MacDonald for administrative assistance

3.0 COMMONLY-USED ACRONYMS AND ABBREVIATIONS

ADCP – Acoustic Doppler Current Profiler

COMFIT – Community Feed-in Tariff

DFO – Department of Fisheries and Oceans (Canada)

FERN – Fundy Energy Research Network

FORCE – Fundy Ocean Research Centre for Energy

MRC – Marine Renewables Canada

OERA – Offshore Energy Research Association of Nova Scotia

NSERC – National Science and Engineering Research Council

R&D – Research and Development

SEA – Strategic Environmental Assessment

4.0 SYMPOSIUM & FORUM PROGRAMME

Nova Scotia Tidal Energy Research Symposium & Forum 14-15 May 2013, Acadia University, Wolfville, NS

Day 1 - Tuesday, May 14th

8:30 - 9:10 **Registration**

9:10 - 9:35 **Opening and Welcoming Remarks**

Graham Daborn, Acadia University

Tom Herman, VP Academic, Acadia University

Murray Coolican, Deputy Minister, Nova Scotia Department of Energy

Stephen Dempsey, Executive Director, Offshore Energy Research Association of Nova Scotia (OERA)

9:35 - 10:10 **Presentations: Updates on Marine Renewable Energy in Nova Scotia**

FORCE: Activity in the Minas Passage, *Doug Keefe, Executive Director, FORCE*

Digby Gut and Passages: Hydrodynamic Site Assessment Project, *Richard Karsten, Acadia University*

Cape Breton Strategic Environmental Assessment, *Russell Dmytriw, AECOM*

Community & Business Tidal Energy Toolkit: Supporting Tidal Energy Development in NS, *John Colton, Acadia University*

10:10 - 10:30 **Break**

10:30 - 12:00 **Technical Presentations**

FORCE's Sensor Platform Project, *Tony Wright, FORCE*

Turbulence Measurement in High Speed Tidal Channels: Results from an Initial Experiment, and Future Directions, *Alex Hay, Dalhousie University*

Cross-coupling between Device-level CFD and Oceanographic Models Applied to TISECs in Minas Passage and Petit Passage, *Richard Karsten, Acadia University*

Mapping the Bay of Fundy, *John Shaw, Geological Survey of Canada*

Seasonal Change in Grain Size and Erodibility on a Tidal Channel-flat Complex in Kingsport, N.S., *Brent Law, Fisheries & Oceans Canada*

12:00 - 1:15 Lunch

1:15 - 2:05 Research & Development: Priorities and Collaboration

OERA Priorities & Collaboration, *Stephen Dempsey, OERA*

University of Massachusetts Research & Collaborations, *Dan MacDonald, University of Massachusetts, Dartmouth*

International Social Science Research Priorities in Marine Renewable Energy, *Shelley MacDougall, Acadia University*

2:05 - 3:00 Breakout Session: Collaboration & Engagement in Tidal Energy Research & Development

3:00 - 3:15 Break

3:15 - 3:30 Report back from Breakout Session groups

3:30 - 4:15 Panel Discussion: Financing Research & Development

Financing, Risk & Tidal Energy, *Shelley MacDougall, Acadia University*

Developing Tidal Feed-in Tariffs for Nova Scotia, *Geoff Keith, Synapse*

Financing Marine Renewable Energy Research, *Carey Ryan, OERA*

Strategy for Partnerships & Innovation, *Richard Isnor, NSERC*

4:15 - 4:25 Day 1 Overview

5:00 - 7:00 Reception and Research Posters

Day 2 - Wednesday, May 15th

8:30 - 9:00 Registration

9:00 - 9:05 Day 2 Welcome, *Graham Daborn, Acadia University*

9:05 - 10:30 Technical Presentations

A Review of Water Velocity and Tidal Height Data Obtained in and Around the FORCE Demonstration Site, *Simon Melrose, Oceans Ltd.*

Getting Plugged In: Assessment of Cable Lay Operations for Tidal Energy Developments in the Minas Passage, *Dean Steinke, DSA Ltd.*

Measurement of Long-Term Ambient Noise and Tidal Turbine Levels in the Bay of Fundy, *Bruce Martin, JASCO*

Sediment-laden Ice: Is it a Serious Impediment to Subsurface Tidal Turbines in Minas Passage? *Brian Sanderson, ACER*

Criteria for Site Selection of Tidal Power In-Stream Devices: The Importance of the Geological Environment, *Jon Mackie, Seaforth Geosurveys*

10:30 - 10:50 Break

10:50 - 12:20 Technical Presentations

Intertidal Sediment Dynamics: Challenges, Lessons Learned and Potential Impacts of Tidal Power Development, *Danika van Proosdij, Saint Mary's University*

Development of Temporal Monitoring Techniques for Benthic Habitat Impacts of Tidal Energy, *Craig Brown, McGregor Geoscience Ltd.*

Assessment of Zooplankton Injury and Mortality from the Deployment of Underwater Tidal Energy Turbines, *David Schlezinger, University of Massachusetts, Dartmouth*

Use of Hydroacoustic Telemetry to Detect Movements of Migratory Fishes and Lobsters in the Minas Passage, *Anna Redden, Acadia University*

Passive Acoustic Monitoring of Harbour Porpoise at the FORCE site in Minas Passage, *Jason Wood, Sea Mammal Research Unit Ltd.*

12:20 - 1:30 Lunch

1:30 - 2:30 Breakout Session: Solutions to Research Challenges

2:30 - 3:00 Reporting Back from Breakout Session groups

3:00 - 3:10 Next steps moving forward / Closing remarks, *Anna Redden, Acadia University*

3:10 - 3:30 Refreshments/Networking

Research Poster Session (Day 1 afternoon)

Poster Contributions from Nova Scotia

1. Seasonal Variability of Total Suspended Matter in Minas Basin, Bay of Fundy, *J. Tao, P.S. Hill and R.P. Mulligan*
2. Seasonal Control of Biofilms on Sediment Erosion from an Intertidal Mud Flat in Kingsport, NS, *J.C. Garwood and P.S. Hill*
3. Modeling the Impact of Large-Scale Tidal Power on Sediment Texture in the Bay of Fundy, *S. Gelati and P.S. Hill*
4. Seasonal Sedimentation and Hydrodynamics in a Bay of Fundy Tidal Creek and Salt Marsh System, *E. Poirier, D. van Proosdij and T. Milligan*
5. Geometry and Composition of Ice Banks in a Macrotidal Channel, *C. Black and P.S. Hill*
6. On the Melt Rate of Submerged Sediment-Laden Ice, *G. Trowse and A. Hay*
7. Measurements and Simulations of the Flow in Digby Neck Passages, *J. McMillan, A. Hay, R. Karsten, R. Schillinger and G. Trowse*
8. High Resolution Numerical Modelling of Digby Neck Passages, *M. O'Flaherty-Sproul, R. Karsten, J. McMillan, G. Trowse and A. Hay*
9. Introducing a Dynamic Penetrometer for Geotechnical Tidal Energy Converter Site Assessment and Monitoring, *N. Stark, A.E. Hay, J.M. McMillan, G. Trowse and A. Kopf*
10. Pathways of Effects for Marine Renewable Energy in Canada, *L. Isaacman and G. Daborn*
11. Electrical Design Considerations of Submarine Power Cables, *A.M. MacNeill, M.E. El-Hawary and S. Molloy*
12. The Fundy Energy Research Network: Fostering Tidal Energy Research Collaborations in the Bay of Fundy, Canada, *L. Isaacman, A.M. Redden and G. Daborn*
13. Riding the Tide is No Bore: Temporal and Spatial Movement Patterns of Striped Bass in the Minas Passage, Bay of Fundy, *F. Keyser, J. Broome and A.M. Redden*
14. Acoustic Detection Ranges for Marine Mammal Monitoring at a Tidal Turbine Site: Grand Passage, NS, *C. Malinka, A.E. Hay, R.A. Cheel and M. Wood*
15. Seasonal Migration of the American Lobster, *Homarus americanus*, through the FORCE Tidal Turbine Test Site and Minas Passage, Bay Of Fundy, *K. Morrison, J. Broome and A. Redden*

16. Bottom Substrate and Associated Epifauna at the FORCE Tidal Turbine Test Site, Minas Passage, Bay of Fundy, *K. Morrison, P. Stewart and A. Redden*
17. The Commotion in the Ocean – Detecting Harbour Porpoises (*Phocoena phocoena*) at the FORCE Turbine Test Site in the Minas Passage, Bay of Fundy, *P. Porskamp, J. Broome, J. Wood and A. Redden*
18. Observations of Harbour Porpoise (*Phocoena phocoena*) at the Fundy Tidal Energy Demonstration Site, Minas Passage, Nova Scotia, 2009-2012, *P. Stewart and F. Lavender*
19. Fundy Tidal Energy Demonstration Site, Seabird Surveys—Minas Passage, 2008-2012, *P.L. Stewart, F.L. Lavender and H.A. Levy*
20. The Levelized Cost of Energy and the Importance of Cash Flow Risk Analysis, *L. Visentin*

Poster Contributions from University of Massachusetts - Dartmouth

1. Macro to Micro: Finding the Sweet Spot for Marine Hydrokinetic Technology Deployments, Muskeget Channel Case Study, *M.A. Bartlett, J.L. Benson, B.L. Howes, R.I. Samimy, D.R. Schlezinger and D. White*
2. Analysis of a Diffuser-Shrouded High-Solidity Vertical Axis Tidal Turbine Using Computational Fluid Dynamics, *P. Chaterjee and R. Laoulache*
3. Accelerated Computational Simulations of Incompressible Multi-Phase Flows in a Parallel Heterogeneous Multi-GPU/CPU Computing Framework, *S. Codyer, M. Raessi and G. Khanna*
4. The Near-Shore Point Absorbing Wave Energy Converter, *B. Green, D. MacDonald, C. Nathan, A. Lopes and J. Cantara*
5. The Impact of Tidal Stream Turbines on Circulation and Sediment Transport in Muskeget Channel, MA., *A. Hakim, G. Cowles and J. Churchill*
6. Oceanographic Data Collection for Environmental Assessment and Siting of Marine Renewable Energy Projects, *B. Howes, R.I. Samimy and D.R. Schlezinger*
7. SMAST Yellowtail Flounder Bycatch Avoidance System, *C. O'Keefe and G. DeCelles*
8. SMAST Sea Scallop Video Survey, *K. Stokesbury*

5.0 TECHNICAL PRESENTATION ABSTRACTS

MARINE RENEWABLE ENERGY POTENTIAL IN COASTAL CAPE BRETON AND THE BRAS D'OR LAKES

Russell Dmytriw

AECOM

(russell.dmytriw@aecom.com)

On behalf of the Offshore Energy Research Association of Nova Scotia (OERA), an AECOM team (Cape Breton University, the Unima'ki Economic Benefits Office, Atlantic Marine Geological Consulting, Oceans Ltd. and AECOM) prepared a Background Study identifying areas of interest (AOIs) for marine renewable energy (MRE) in Cape Breton. The Background Study is a reference report for the Strategic Environmental Assessment (SEA) that will help determine the future of MRE projects in Cape Breton. AOIs were selected based on the available energy resource and the MRE device technical & operating parameters. Wind and wave energy resource maps have been prepared for this region but the tidal resource is less well known. Four coastal tidal AOIs (Mabou-Cheticamp, Cape North-St. Paul Island, Scaterie-Flint Island and Gabarus-Forchu) and two interior AOIs (Great Bras d'Or Channel and Barra Strait) were identified.

Current speeds in coastal areas are poorly mapped. Given the long coastline and numerous headlands that accelerate current speeds, the total energy is expected to be high; these areas are potentially suitable for tidal arrays. Conversely, there is an elevated potential for area use conflicts due to the variety of commercial fishing activities and the prominent social and economic value of these activities.

The Bras d'Or Lakes are a UNESCO site, a unique ecosystem and are widely used for recreation. Arrays may impede tidal flow resulting in far field energy extraction effects. Current speeds and thus total energy are low but adequate for technology demonstration, research and distribution of tide-generated electricity to local communities.

THE COMMUNITY AND BUSINESS TIDAL ENERGY TOOLKIT: SUPPORTING TIDAL ENERGY DEVELOPMENT IN NOVA SCOTIA

Shelley MacDougall^{1,2}, John W. Colton^{2,3} and Alan Howell²

¹ School of Business, Acadia University, Wolfville, NS

²Acadia Tidal Energy Institute, Wolfville, NS

³Community Development, Acadia University, Wolfville, NS

(john.colton@acadiau.ca)

The Community and Business Toolkit for Tidal Energy Development was proposed in response to Nova Scotia's growing involvement in tidal energy development, coupled with its renewable energy targets. Focusing on both community-based and large-scale tidal energy development, the purpose of the Toolkit was to collect and synthesize what is known about tidal energy technologies under development, tidal flows in the Bay of Fundy, community and business impacts and opportunities, financing constraints, engineering challenges, and environmental, social and financial risks and how to mitigate them. *The Community and Business Toolkit for Tidal Energy Development* was the collaborative work of researchers from a broad range of disciplines (engineering, mathematics and statistics, biology, environmental science, finance, economics, sustainable communities, rural economic development), in consultation with community, industry and government stakeholders of tidal energy. The output is a comprehensive coverage of the issues, challenges and opportunities of developing tidal energy in Nova Scotia and elsewhere. It informs policy makers, municipal counsellors, device and project developers, financiers, community members and other users of the water, thereby empowering stakeholders and helping to ensure the development of tidal energy is environmentally, socially and economically sustainable. The development and release of the Toolkit is significant because no other document currently exists in the world that brings together the scientific *and* socio-economic issues that reflect the reality of tidal energy development. Just as significant is the degree of collaboration among the many contributors from the university, private and government sectors. The presentation provides a brief overview of its development and explores ways in which the toolkit can support sustainable tidal energy development.

TURBULENCE MEASUREMENT IN HIGH SPEED TIDAL CHANNELS: RESULTS FROM AN INITIAL EXPERIMENT, AND FUTURE DIRECTIONS

Alex E. Hay, Richard Cheel, Justine McMillan and Doug Schillinger

Ocean Acoustics Lab, Department of Oceanography, Dalhousie University, Halifax, NS

(Alex.hay@dal.ca)

Results will be presented from a first turbulence measurement experiment in Grand Passage, NS, carried out in September 2012. The experiment was part of a wider effort to contribute to the knowledge base of flow conditions required for tidal power site assessment and development in Nova Scotia. Knowledge of turbulence is needed both near the sea bed, where stress on cables is an important issue, and in mid-water column at the so-called hub-height, where turbulent velocity fluctuations impact turbine design and performance. For this experiment, an instrumented lander was deployed on the seafloor. The deployment site, selected on the basis of high resolution mapping with multi-beam sonar, was characterized by coarse sand and gravel and shell hash molded by the flow into 8 m wavelength, nearly 1 m high dunes. On board the lander were two turbulence sensors: an acoustic Doppler velocimeter, and a time-of-flight acoustic flowmeter. An upward-looking Acoustic Doppler Current Profiler (ADCP) sampling at nearly 2 Hz was deployed nearby using a second lander. The presentation will include discussion of the flow and turbulence measurements in the bottom boundary layer and in mid-water column, highlighting those things which worked and those which did not, and leading to an outline of our plans for testing new approaches for turbulence measurement at hub-height during the upcoming field season.

CROSS-COUPLING BETWEEN DEVICE-LEVEL CFD AND OCEANOGRAPHIC MODELS APPLIED TO TISECS IN MINAS PASSAGE AND PETIT PASSAGE

Voytek Klaptocz¹, Timothy Waung¹, Curran Crawford², Michael Shives², Richard Karsten³, Clayton Hiles⁴ and Roy Walters⁴

¹ Mavi Innovations Inc.

² University of Victoria

³ Acadia University

⁴ Cascadia Coast Research

(voytek@mavi-innovations.ca)

This project set out to develop a link between Oceanographic computer models and Computational Fluid Dynamics (CFD) models in order to improve state of the art modeling techniques used for resource assessments and tidal turbine siting for both single and multiple in-stream tidal turbines. What follows is a summary of the project's methods and results. A full report on the project is available at:

<http://www.oera.ca/marine-renewable-energy/tidal-research-projects/hydrodynamic-modeling/cross-coupling-between-device-level-cfd-and-oceanographic-models-applied-to-multiple-tiseecs-in-minas-passage/>

The research was completed in two phases:

1. CFD modeling and flume tank experiments of single and multiple turbine analogues (porous discs) in a straight channel;
2. A case study modeling single and multiple turbine analogues in Minas Passage and Petit Passage.

Experiments were completed in the flume tank at the University of Victoria to measure thrust and study downstream wake dissipation for turbine arrays. Porous discs mounted on force-measurement rigs in the flume tank were used to represent the turbines. Particle image velocimetry (PIV) measurement equipment was used to visualize and quantify the wake structures behind the disks. The PIV system provided very rich flow-field data for a variety of array configurations clearly showing disc interactions and wake structure. Data from the experimental results were subsequently used to validate the turbine thrust and wake field computed using the CFD and Ocean models.

It was found that the CFD simulations did a reasonable job in predicting the thrust force acting on porous discs in several different array configurations. For all cases considered as part of this project, the thrust was predicted within 8% of the experimental results. The CFD simulations also did an adequate job in predicting the wake recovery behind porous discs; however, significant tuning of turbulence parameters was required to get a good match to experimental data. The fact that thrust forces for each of the turbines can be predicted with reasonable accuracy and the wake can be tuned will allow site developers to use this simplified

method for planning the initial layout of turbine arrays. Investigations of the PIV and CFD predictions after the project revealed that the CFD results agreed much better with experimental data when the CFD data were extracted along a plane inclined to the axis of the tunnel. This indicates that the wakes are in fact inclined upward downstream of the discs, and a more detailed investigation of this effect, also seen in results obtained by other research groups, is underway.

A team workshop was hosted by the University of Victoria on July 10th, 2012 to brainstorm CFD – Ocean model coupling approaches. Two cross-coupling methods were identified at the workshop:

- i. Mid-Field CFD model: 100s of meters or even few km in size (see Figure 1)
- ii. Near-Field CFD model: 10s of meters, only spanning one or few Ocean model elements around the turbine(s) (see Figure 2)

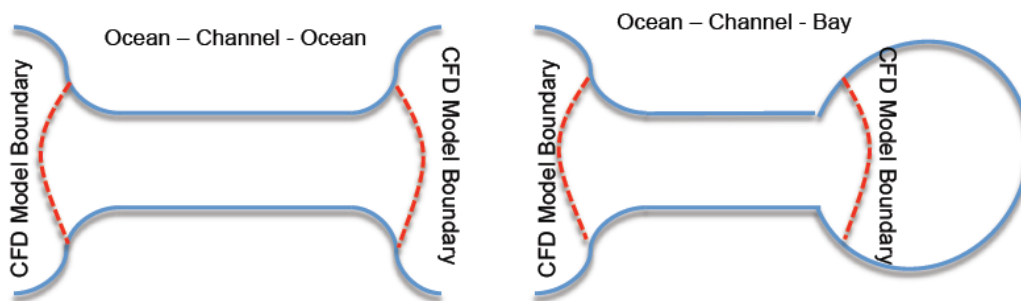

Figure 1. Mid-field CFD model approach

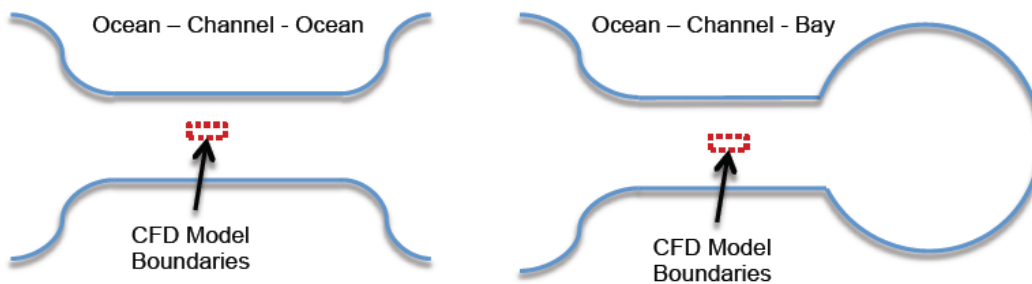

Figure 2. Near-field CFD model approach

One of the key objectives of this project was to apply these cross-coupling methods to tidal sites in Nova Scotia. At the project outset, it was anticipated that all of the work would be applied to modeling the flows through Minas Passage with inclusion of four turbines at the test berths. As the project progressed, and the two different cross-coupling approaches were identified, the team decided to include Petit Passage as a case study for testing the mid-field CFD approach while Minas Passage was used for testing the near-field approach.

The near-field modeling approach was tested on the Minas Passage site by modeling four 16m diameter turbines, one at each of the FORCE test berths. Each of the four turbines was first modeled in CFD (as a porous disk) in a 200m x 200m area surrounding each berth with inclusion

of detailed bathymetry. Inflow and turbulence conditions were sourced from the Ocean model for the peak flood. To simplify the analysis only the M2 tidal component was used to drive the system. At peak flood (nominally $U=2.5\text{m/s}$) the total estimated power production in the Ocean model was 5MW.

The near-field coupling method work shows great promise. The objective was to ensure consistency between the Ocean and CFD models and in large part this was achieved. This methodology has a range of potential applications including:

- estimation of total extractable power from a tidal system;
- informing wide tidal site selection;
- array layout and channel build-out;
- investigation of the impact of a tidal installation on current patterns and tidal range; and
- investigation of the impacts of tidal installations on one another, etc.

With this methodology in place, regulators, developers and other stakeholders in the tidal industry can virtually investigate any number of 'what if' scenarios for the installations of free stream turbines before ever driving a pile or laying cable.

The mid-field cross-coupling method was also successfully implemented and demonstrated for Petit Passage. The flow through Petit Passage was modeled for both ebb and flood conditions (6 h each). In general, results from the CFD simulations showed good agreement with Ocean model data, especially where the flow is relatively uni-directional and not dominated by large eddies.

A methodology was also proposed and subsequently demonstrated for how best to use the mid-field modeling approach to identify suitable turbine deployment locations. A deployment location along the north eastern shore of Petit Passage was identified as a possible turbine deployment site. A simulation was subsequently run with the inclusion of a turbine. This simulation demonstrated the potential for using CFD to calculate power extracted by the turbine over a tidal cycle as well as modeling the wake generated by the turbine. This methodology could therefore be extended to modeling tidal farm arrays with inclusion of turbine interaction effects.

At this point, the CFD model of Petit Passage is still considered preliminary because it has not been validated against field data. While ADCP measurements have been completed at several locations in Petit Passage, the data is not yet available for public release.

The team therefore succeeded in meeting initial project objectives by testing two separate methods of coupling CFD and Ocean models. Detailed models of both Minas Passage and Petit Passage now exist that can be used as tools by project developers for laying out turbine arrays and technology developers to better understanding local inflow conditions.

MAPPING THE BAY OF FUNDY

John Shaw, Brian J. Todd and Michael Z. Li

Geological Survey of Canada Atlantic, Bedford Institute of Oceanography, Dartmouth, NS
(johnshaw@nrcan.gc.ca)

The Bay of Fundy, Canada has been systematically mapped twice by the Geological Survey of Canada. The 1977 surficial geology map depicts the seafloor in the context of the standard formations approach used on Atlantic Canada's continental shelf. The more recent mapping utilised multibeam sonar technology and resulted in a series of seventeen 1:50,000-scale maps of shaded seafloor relief (containing descriptions of geomorphology) and backscatter (containing descriptions of textural properties). A resulting series of journal papers (published and in press) highlighted the glacial history of the bay, the evolution of Minas Passage, the physical characteristics of the Minas Passage scour-trough system, the dynamics of the Scots Bay dune field, and the bedforms assemblages throughout the bay. The final product of the second phase was a 'Seascape' map, in which the seafloor was classified in terms of morphology, texture, and biota into eight broad classes: 1) bedrock; 2) glacial; 3) glaciomarine; 4) muddy; 5) scoured; 6) sandy; 7) biological; and 8) anthropogenic. Within the classes, many seascape units were identified, including 7 sandy seascapes that reflect the great variety of bedforms in the bay. The second phase of mapping reveals the great complexity of the seafloor and highlights the difficulty inherent in attempting to characterise the regional textural properties based on bottom samples.

SEASONAL CHANGE IN GRAIN SIZE AND ERODIBILITY ON A TIDAL CHANNEL-FLAT COMPLEX IN KINGSPORT, N.S.

Brent A. Law^{1,2}, Timothy G. Milligan¹, Paul S. Hill², Gary L. Bugden and V. Zions¹

¹Department of Fisheries and Oceans (DFO), Canada, Bedford Institute of Oceanography, Dartmouth, NS

²Department of Oceanography, Dalhousie University, NS

The extreme effect of energy extraction in the Bay of Fundy was demonstrated by reduction of tidal flow due to the construction of causeways in the late 1960's. Concern over possible change to the sediment dynamics in the Upper Bay of Fundy due to tidal energy extraction from in-stream tidal power is warranted. In April 2012, a study funded by the Offshore Energy Research Association of Nova Scotia (OERA) was initiated to examine the seasonal change in grain size and erodibility on a tidal flat and channel complex in Kingsport, NS. Sixty-two samples were collected for grain size analysis every month with 42 from the tidal flat and 21 from a tidal channel and its banks. Erodibility measurements were made monthly with a Gust microcosm erosion chamber on duplicate samples from the tidal flat, left and right tidal channel bank, and the channel thalweg. The monthly sampling was completed in March 2013. Results from this study will add to a baseline set of data being collected by researchers in the tidal power community, and it will provide the parameters necessary to run coupled sediment-hydrodynamic transport models. These models will be used to explore and quantify the possible effects of in-stream tidal power on the ecosystem. This talk will focus on the results from the OERA study and will also briefly describe a DFO lead Hudson cruise to the Minas Basin area, which is scheduled for June 2013.

SOCIAL STUDIES RESEARCH IN MARINE RENEWABLE ENERGY: RESEARCH PRIORITIES IDENTIFIED BY THE INTERNATIONAL NETWORK FOR SOCIAL STUDIES OF MARINE ENERGY (ISSMER)

Shelley MacDougall¹, John Colton¹, Sandy Kerr², Laura Watts³ and Kate Johnson²

¹Acadia Tidal Energy Institute, Acadia University, NS, Canada

²Heriot-Watt University, Scotland, United Kingdom

³IT University of Copenhagen, Denmark

(shelley.macdougall@acadiau.ca)

The International Network for Social Studies of Marine Energy (ISSMER) was established in 2012 to bring together researchers of the social sciences and humanities interested in conducting international and interdisciplinary research related to marine renewable energy, specifically, wave, tidal and offshore wind energy.

Social studies are defined as "the integrated study of the social sciences and humanities to promote civic competence. [Social sciences] include anthropology, archaeology, economics, geography, history, law, philosophy, political science, psychology, religion, and sociology, as well as appropriate content from the humanities" (National Council for the Social Studies, 2013). Disciplines in the humanities include languages, literature, philosophy, religion and the visual and performing arts (Study Portals, 2013). These lists are by no means exhaustive.

Marine Renewable Energy Research

To date, most of the academic research conducted on marine renewable energy has been in the pure and applied sciences. More specifically, this research has tended to focus on resource assessment, technology development and environmental impacts. The success of marine energy projects is contingent on public understanding and represents potentially significant change to the human use of coastal waters.

Increasingly, the need for socio-economic research is noted as important for the successful development of marine renewable energy. However, social economics is one of many branches of economics within the many disciplines that constitute social studies. Research for the responsible development of renewable energy needs to draw on a multitude of social studies disciplines.

ISSMER Launch Workshop

The inaugural workshop of the International Network for Social Studies of Marine Energy took place in Stromness, Orkney, UK in September 2012. Funded by the UK Natural Environment Research Council, its purpose was to explore the social science and humanities research issues emerging in marine renewable energy. The researchers in attendance were from the UK, Europe, Canada and the USA and represented the spectrum of social studies research.

The workshop participants gathered for focused conversations with local stakeholders, advocates and opponents of marine renewable energy development. These guests included technology developers, site developers, a marine planner, the Director of the European Marine Energy Centre, infrastructure planners, supply chain business operators, residents, local artists and literary authors, a farmer and a representative of local fishers.

Following the conversations, the researchers collaborated to identify the research topics that had emerged from the discussions and establish a social studies research agenda. The research topics were grouped into nine broad themes. The themes and topics are briefly summarized in Table 1.

Table 1: Social Studies Research in Marine Renewable Energy - Research Priorities

- 1) Communication and knowledge flow
 - Models for knowledge-making and innovation that include local knowledge (beyond traditional government-industry-academia model).
- 2) Economic effects
 - The “net” effect of job creation and job migration, supply chain and infrastructure readiness, stickiness of expenditures to local economy, non-market impacts.
- 3) Wealth distribution & community benefits
 - Trade-offs between loss of local amenity rights and economic gain or community benefit.
- 4) Consultation and participation
 - Effective engagement and consultation processes.
- 5) Future uncertainty
 - Location and scale, physical characteristics, financial viability, extent of impacts.
- 6) Public attitudes
 - Effect of location-specific socio-cultural context on attitudes toward marine renewable energy development over time.
- 7) Planning processes
 - Interface between land and sea planning systems; engage local expert and tacit knowledge.
- 8) Comparative studies
 - Evolution and deployment of analogous technologies (oil and gas, offshore wind, various jurisdictions).
- 9) Other issues
 - Political fluctuations, financial crisis, changing power relationships, private rights in a commons.

Source: Kerr *et al.* (2013)

The full ISSMER workshop report can be downloaded from <http://www.issmer-network.org/news/issmer-strategic-report/>. A journal article, which will discuss the importance of these topics, draw on relevant research and describe the future research needed, is in progress.

References

Kerr, S., Watts, L. and Johnson, K. (2013). Workshop Report: Establishing an Agenda for Social Studies in Marine Renewable Energy, International Network for Social Studies of Marine Energy. Retrieved from: <http://www.issmer-network.org/news/issmer-strategic-report/>.

National Council for the Social Studies (2013). Retrieved from: <http://www.socialstudies.org>.

Study Portals (2013). Retrieved from: <http://www.bachelorsportal.eu/disciplines/9/humanities-art.html>.

GETTING PLUGGED IN: ASSESSMENT OF CABLE LAY OPERATIONS FOR TIDAL ENERGY DEVELOPMENTS IN THE MINAS PASSAGE

Dean Steinke, Andrew Baron and Darren Weaver

Dynamic Systems Analysis Ltd., Halifax, NS

(Dean@dsa-ltd.ca)

Introduction

The laying of subsea electrical transmission and communications cables that will connect tidal energy turbines to the grid is key to the successful harnessing of the power of the world's highest tides in the Bay of Fundy. The Fundy Ocean Center for Energy (FORCE) is presently developing tidal energy infrastructure in the Minas Passage, including the installation of subsea cables. However, there is no direct experience in laying cables in the Minas Passage in tidal flow velocities of 5.5m/s; uncertainty and risks must be identified and addressed to successfully connect turbines to the grid.

There are many challenges associated with cable laying in the Minas Passage, such as: the short operational window, limited information regarding cable stability on the seabed, cable routing uncertainties, and seakeeping power limitations for conventional cable lay vessels or tug and barge outfits. To reduce risk, in-water experience is needed in the Minas Passage and other areas in the Bay of Fundy. However, sea trials and real-world tests can be costly. To reduce the number of sea trials and the risk of cable lay operations Dynamic Systems Analysis Ltd. (DSA) has worked with FORCE to simulate cable lay operations using its numerical modeling software ProteusDS. The analysis has focused on assessing the expected loads on the cable lay vessel in both the extreme (flood and ebb) and expected deployment conditions.

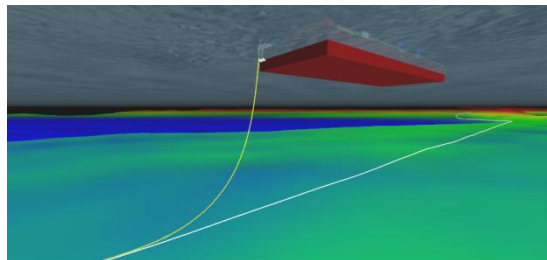

Figure 3. Screen shot of ProteusDS post-processing software. Cable route shown in white, power cable shown in yellow.

Cable Lay Background

Telecommunications cables have been laid for over a century and a half, with the transatlantic telegraph cable being completed in the mid 19th century. Cable lay operations typically take place from barges or specially built cable lay vessels. Barges are often used in shallow waters so they can rest on the seabed during low tide, and are typically lower cost than specialty vessels. One of the challenges for cable lay operations is ensuring that an acceptable cable route is found to minimize the chance of cable damage. Large cliffs, boulder fields and high slopes should be

avoided. It is typically desirable to ensure that cable is laid at a sufficiently low bottom tension to prevent any bridging or suspensions on the seabed between boulders or other gaps in the seabed. Cable suspensions can result in undue wear on the cable due to wave and current action. In addition, the cable must be laid at a sufficiently high tension to ensure that no excess cable is laid, and that when the cable is being deployed small bending radii are avoided at the cable touch down point. Understanding the interaction of current forces on cable lay operations in high current environments is important.

Project Objectives

The project had several objectives; firstly, the potential loading on the barge due to the power cable was to be assessed. In addition, the tensions in the cable due to both environmental loading and cable self-weight were to be examined to ensure that cable damage was avoided.

Simulation Platform: ProteusDS

To assess cable lay operations, DSA modeled the power cable using its software ProteusDS. ProteusDS has a range of built-in models used to study systems in the ocean. Cables, nets, ships and offshore structures, rigid bodies and mechanisms can be created, controlled and studied with the software (Steinke *et al.*, 2008). The software provides a suite of environmental and engineering models that can be used to study various ocean engineering applications, such as cable lay. Models include:

- Irregular and regular wave models
- Spectral wind models
- Finite-element cable model (power cables, risers, moorings, pipelines)
- 6 DOF rigid body model (towed bodies, ships, buoys)
- Nonlinear and linear seabed contact model
- Seabed bathymetry modeling capability

ProteusDS is validated through the creation of simulation test cases. These tests are created throughout the software development process. The result of each validation test is either compared against analytical solutions or experimental results. Each model, especially the more complex ones, typically has several independent validation tests to ensure each feature of a model operates reliably. Typical tests include: beam deflection stress tests, hydrodynamic loading tests, pendulums tests or wave loading test.

Simulation Setup

Current profiles expected during the operations were provided by FORCE based on Acoustic Doppler Current Profiler (ADCP) data collected in the FORCE crown lease area. A power law current profile was used to estimate the current profile in the boundary layer between 0 and 1.5m elevation from the seabed (Soulsby, 1997). Free stream current velocities of 0.4, 1.2, 2.4, 3.7 and 4.9 m/s were simulated at various expected headings. The raw current profiles were used between 1.5m elevation and the sea surface.

A bathymetric mesh was generated for use in the simulations based on multi-beam bathymetry data. This captured the general changes in depth, but did not capture detail on the level of boulders. A more accurate mesh was developed later in the project but was not used; it was recommended that the more detailed mesh be used for future work.

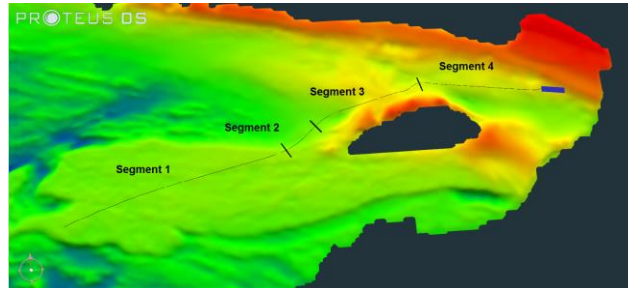

Figure 4. Bathymetric mesh used in ProteusDS plus simulated cable lay segments 1-4

The power cable is 0.143m in diameter, with a mass per unit length of 39.2kg/m. The cable was paid out at 0.5 knots and the barge advanced at 0.5 knots.

Results

During nominal conditions (~1 knot current), the reaction forces on the barge due to the power cable are minimal (4.5kN in surge and 5.3kN in sway) and were not expected to have a large impact on the barge operations. The bending radius at the touch down point was also large (>115m), so it was deemed that danger of bending damage would be minimal.

In extreme currents high cable loading was seen (132kN in surge and 207kN in sway). It was seen that cable loading was increased when the cable lifted off of the seabed. This is because the current velocity is very low near the seabed so the hydrodynamic drag which causes the reaction forces on the barge are minimized. However, once the cable is in the water column, high current velocities induce large drag loads.

Conclusions

Inclusion of barge dynamics and a more detailed seabed model was seen to be important for future work. The simulation project allowed the team to better assess cable lay operations and reduce risk for the actual deployment. It quantitatively answered many questions about loading needed for operational planning of cable lay activities.

References

Steinke, D., Buckham, B.J., Nicoll, R., Design through Simulations: Finite Element Capabilities for Ocean Engineering, *Proceedings of the 27th International Conference on Offshore Mechanics and Arctic Engineering*, Estoril, Portugal, June 15-20, 2008

Soulsby, R., *Dynamics of Marine Sands: A Manual for Practical Applications*, Thomas-Telford, 1997

MEASUREMENT OF LONG-TERM AMBIENT NOISE AND TIDAL TURBINE LEVELS IN THE BAY OF FUNDY

Bruce Martin¹, Christopher Whitt¹, Craig Mcpherson¹, Andrew Gerber², Murray Scotney³

¹JASCO

²University of New Brunswick

³OMTS

(Bruce.Martin@jasco.com)

JASCO Applied Sciences has been tasked with performing long term measurements of sound levels in the Bay of Fundy, at the Fundy Ocean Research Center for Energy (FORCE), where tidal current can exceed 6 m/s. The goal of the project is to measure sound levels while the turbines are operating at full tidal flow. In the fall of 2011 JASCO began deployments of its high flow mooring designed to minimize acoustic pseudo-noise associated with flow so that real acoustic measurements could be made. A variety of mooring configurations and hydrophone placements have been evaluated. This presentation discusses the mooring designs, the lessons learned from JASCO's deployments, and ambient noise data collected using the equipment. Computational fluid dynamics models of the acoustic and mechanical performance of one of the moorings performed by the University of New Brunswick will also be presented.

SEDIMENT-LADEN ICE: IS IT A SERIOUS IMPEDIMENT TO SUBSURFACE TIDAL TURBINES IN MINAS PASSAGE?

Brian G. Sanderson, Anna M. Redden and Jeremy Broome

Acadia Centre for Estuarine Research, Acadia University, Wolfville, NS

(bxs@eastlink.ca)

The spectre of huge ice cakes drifting in the mid water-column has been proposed as a potential impediment to the operation of submerged tidal turbines. We conducted a study in which ice cakes have been sectioned, using hand tools, into multiple samples and Archimedes Principle used to measure densities. Such measurements have been made at multiple locations and at different times during two ice seasons. Density of frozen sediment was also measured. Measurements confirmed that highly stained ice cakes were very buoyant. Density of samples had a bimodal distribution, most being distinctly buoyant. A small number of samples incorporated intact frozen sediment (either rock or mud), which is distinctly more dense than seawater. Physical scaling requires that the larger an ice cake the more closely its density must match that of seawater in order for the ice cake to be entrained into the interior of the water column. Ice cakes are made from three types of material (ice, air pockets and sediment) two of which are much less dense than seawater and the other much denser. These disparate materials must be "assembled" in just the "right" combinations for a near neutrally-buoyant ice cake to result. Consideration of the sequence of mechanisms required to create a large, near neutrally-buoyant ice cake --- and consideration of the structural properties of ice cakes --- leads us to conclude that ice cakes do not pose a serious risk to well-engineered tidal turbines.

CRITERIA FOR SITE SELECTION OF TIDAL POWER IN STREAM DEVICES: THE IMPORTANCE OF THE GEOLOGICAL ENVIRONMENT

Gordon B.J. Fader¹ and Jon Mackie²

¹Atlantic Marine Geological Consulting Ltd.

²Seaforth Geosurveys

(jmackie@seafortheng.ca)

Recent tidal power development in the Bay of Fundy began over six years ago and has progressed to the present stage involving deployment of tidal in-stream devices (TISEC), laying of seabed cables and environmental and engineering monitoring. The criteria for site selection consisted of locating areas that provided appropriate water flow, seabed foundations, water depth, cable routes and a host of environmental concerns. The information collected for the geoscience component of site selection has revealed much about the characteristics and stability of the seabed of the inner Bay of Fundy in Minas Passage and Minas Channel. Areas of the strongest currents are scoured depressions cut into glaciomarine stratified sediments exposing bedrock. Remaining sediments consist of gravel in the granule to boulder range and mud and sand are absent. Instabilities exist along the northern shore of Minas Passage and sediment failures have been identified. To refine cable routes, a reprocessing and interpretation of all of the geoscience data has been recently undertaken, on behalf of FORCE (Fundy Ocean Research Centre for Energy), to understand and quantify changes that have occurred over the past six years. This has provided a very high resolution understanding of seabed stability and characterization. Four test sites have been chosen for deployment of TISEC devices and within each are a variety of gravel and bedrock distributions and associated characteristics. It is important to emphasize that developers need to consider that scoured high energy regions present foundation challenges of gravelly sediments, bedrock and morphology, and that structures need to be designed to be flexible to cope with a variety of seabed conditions.

INTERTIDAL SEDIMENT DYNAMICS: CHALLENGES, LESSONS LEARNED AND POTENTIAL IMPACTS OF TIDAL POWER DEVELOPMENT

Danika van Proosdij^{1,2}, Casey O’Laughlin¹, Emma Poirier¹, Ryan Mulligan³ and Logan Ashall³

¹Department of Geography, Saint Mary’s University, Halifax, NS

²Intertidal Coastal Sediment Transport Research Unit, Saint Mary’s University, Halifax, NS

³Department of Civil Engineering, Queen’s University, Kingston, ON

(dvanproo@smu.ca)

The purpose of this paper is to examine the challenges, lessons learned and potential impacts of tidal power development on sediment dynamics within intertidal ecosystems in the Minas Basin. Hydrodynamics and resultant sediment deposition were recorded over a total of 92 tides over a 4 year period (2009-2013) at 3 sites ranging from an end member salt marsh tidal creek to an open marsh/mudflat system. Sedimentary processes (velocity and suspended sediment concentration) were recorded using a range of acoustic and optical instruments on the marsh surface and in the tidal creek. A minimum of 3 surface mounted sediment traps per instrument station were deployed with over 1000 filters recovered. One third of these filters were processed for Disaggregated Grain Size analysis using a Coulter Multisizer 3. Significant spatial and temporal variability were observed within all systems making it challenging to extrapolate empirical findings to areas outside of the field research site. Overall resolved horizontal velocities were low (5-10 cm/s tidal creek; < 5 cm/s marsh surface). However, velocities greater than 25 cm/s were recorded on the exposed mudflat during storm conditions. Suspended sediment concentrations were highly variable, ranging from 28 mg/l to 5,800 mg/l with highest amounts during storm conditions. Approximately 80% of this material was in flocculated form contributing to almost 7 times more deposition within the creek as compared to the vegetated surface. Results are contributing directly to hydrodynamic and sediment modeling exercises and preliminary models examining the potential environmental effects of tidal energy extraction will be presented.

DEVELOPMENT OF TEMPORAL MONITORING TECHNIQUES FOR BENTHIC HABITAT IMPACTS OF TIDAL ENERGY

Craig J. Brown^{1,2}, Dimitrios Tzekakis^{1,2}, Ulrich Lobsiger¹ and Rodolphe Devillers²

¹McGregor GeoScience Ltd., Bedford, NS

²Memorial University, St. John's, NL

(cbrown@mcgregor-geoscience.com)

Deployment of Tidal In-Stream Energy Conversion (TISEC) devices, including turbines and cables, may impact benthic habitats through the alteration of environmental conditions with subsequent impacts on benthic productivity and diversity. *In situ* sampling methods (e.g. sediment sampling) have been traditionally used to monitor marine habitats with respect to human impacts. However, these methods lack data density and spatial coverage to accurately define habitat heterogeneity and variability across meso- (10 m² – 1 km²) and broad-scales (>1 km²). Acoustic mapping devices (e.g. multibeam echosounders) can encompass broad scale areas with 100% spatial coverage at sub-meter resolutions in shallow coastal waters. Recent developments in acoustic classification methodologies may offer a cost-effective approach for detecting change in seafloor conditions when applied to data from repeat acoustic surveys over the same area. When coupled with the collection and analysis of conventional seafloor sampling techniques (i.e. benthic grab samples and underwater video), this combination of survey methods may offer a suitable approach for monitoring change associated with the deployment of TISEC devices in the marine environment. In the spring of 2012, repeat inter-tidal acoustic and seafloor sampling surveys were conducted over 4 case study sites in the Bay of Fundy as part of an Offshore Energy Research Association of Nova Scotia (OERA) funded research program to assess physical/biological changes in seafloor features over various time-frames. The same areas will be surveyed again in the spring of 2013 to assess any inter-annual changes in seafloor conditions at these sites. Preliminary results suggest these techniques offer potential to measure broad-scale changes in environmental conditions at the seafloor, and an overview of this project to date will be presented.

ASSESSMENT OF ZOOPLANKTON INJURY AND MORTALITY RESULTING FROM THE DEPLOYMENT OF UNDERWATER TURBINES FOR TIDAL ENERGY PRODUCTION

David R. Schlezinger¹, Craig D. Taylor², Roland I. Samimy¹ and Brian L. Howes¹

¹University of Massachusetts, Dartmouth; School for Marine Science and Technology

²Woods Hole Oceanographic Institute, Department of Biology

(dschlezinger@umassd.edu)

Collaborative work between the UMASS-Marine Renewable Energy Center, the Town of Edgartown and the Coastal Systems Program is focused on developing the tidal energy potential of Muskeget Channel. We have undertaken detailed oceanographic and environmental surveys to optimize in-stream turbine power generation and to quantify potential environmental effects. In 2011 and 2012 tidal turbine demonstration projects were conducted in Muskeget Channel to determine the effects of blade strikes, shear stress, turbulence and cavitation on zooplankton. Single turbines may minimally impact zooplankton populations; however, full scale projects may potentially alter zooplankton populations forming the base of coastal food webs. Static plankton tows were performed up and down stream of the operating turbine axis. Integral flow meters allowed adjustment of tow duration to optimize zooplankton density in the concentrate. Samples were held at *in situ* temperatures and sequential photomicrographs and video images were taken to determine particle density, size distribution and the number live organisms in samples taken up and down gradient of the operating tidal turbine within 3 hours of collection. Statistical analysis showed no significant difference in the total number or size distribution of motile zooplankters indicating tidal turbine operation did not cause significant mortality or changes in viability and suggested that impacts of commercial size tidal energy projects upon zooplankton populations in Muskeget Channel may be negligible. Future work will focus on regions of higher current velocities where turbine induced stresses may be greater and determining whether cumulative or synergistic effects may occur in commercial deployments of multiple turbines.

USE OF HYDROACOUSTIC TELEMETRY TO DETECT MOVEMENTS OF MIGRATORY FISHES AND LOBSTERS IN THE MINAS PASSAGE

Anna M. Redden^{1,2}, Jeremy Broome^{1,2}, Freya Keyser^{1,2}, Kaycee Morrison^{1,2}, Montana McLean¹, Rod Bradford³ and Michael J.W. Stokesbury¹

¹Biology Department, Acadia University, Wolfville, NS

² Acadia Centre for Estuarine Research and Acadia Tidal Energy Institute, Acadia University, NS

³ Fisheries and Oceans Canada, BIO, Dartmouth, NS

(anna.redden@acadiau.ca)

Tidal energy developments at the FORCE (Fundy Ocean Research Centre for Energy) site in the Minas Passage have necessitated research to help determine the potential risk of turbine – marine biota interactions. Since 2010, we have been collecting data on the Minas Passage movements of significant species, including those that have been listed as endangered (striped bass), of high conservation significance (Atlantic sturgeon), of special concern (American eel) and of high commercial value (American lobster). Our project uses VEMCO animal tracking technology to track animal movements and behaviour over a scale of kilometres. Receivers placed in lines across both the passage (5 km wide) and the FORCE test site are being used to detect electronic tags surgically implanted in fish, as well as those attached to the carapace of lobsters, to determine how migratory species use the Minas Passage as they migrate into and out of the Minas Basin on a seasonal basis. Results show that the FORCE test area forms part of the migratory corridor for both lobster and fish. Many fish have been shown to make multiple, near daily passes through the passage. Depth within which fish swim varies with species and, for striped bass, varies with maturity. The biggest challenges faced to date are: 1) limited receiver detections of transmissions when ambient noise levels are very high (average water column current speeds >2.5 m/s); and 2) mooring technology and equipment durability (strain at attachment points) and unit movement in high flow environments.

PASSIVE ACOUSTIC MONITORING OF HARBOUR PORPOISE AT THE FORCE SITE IN MINAS PASSAGE

Jason D. Wood¹, Dominic J. Tollit², Anna M. Redden³, Jeremy Broome³ and Lauren Fogarty³

¹ SMRU LLC, Friday Harbor, WA

² SMRU Ltd. Canada, Vancouver, BC

³Acadia Centre for Estuarine Research and Acadia Tidal Energy Institute, Acadia University, NS
(jw@smrullc.com)

Currently, there is sparse information available on the near-field effects of tidal in-stream energy conversion (TISEC) devices on marine mammals. There are also little data on the temporal presence and activity of marine mammals in the upper Bay of Fundy. Harbour porpoise are listed by COSEWIC as a species of special concern and represent the most commonly occurring species of cetacean in Minas Passage/Basin, seen year-round in small pods. While the risk of direct collision or turbine strike remains a potential concern for marine mammals, behavioural or activity level modifications or loss of foraging habitat due to anthropogenic noise disturbance (notably noise during TISEC turbine operation, but also during any foundation construction) and indirectly due to changes in prey populations (such as reef effects due to TISEC turbine presence) are considered two significant data-gaps that need biological assessment. C-POD hydrophones (autonomous cetacean echolocation click detectors) have been deployed in and around the FORCE (Fundy Ocean Research Centre for Energy) site since 2010 to determine baseline activity patterns of Harbour porpoise and how these vary over time and space. Data indicate daily presence of porpoise in Minas Passage at typically low levels from May through November. Porpoise detections vary significantly across time and space. Porpoise detections are highest at night time as well as during the months of July and November. Porpoise detections also vary across relatively small spatial scales (~700m). The unique challenges of collecting acoustic data in tidally dynamic sites will also be discussed.

6.0 RESEARCH POSTER PRESENTATION ABSTRACTS

GEOMETRY AND COMPOSITION OF ICE BANKS IN A MACROTIDAL CHANNEL

CarolAnne Black and Paul S. Hill

Department of Oceanography, Dalhousie University, Halifax, NS

(carolanne.black@dal.ca)

Large ice blocks containing enough sediment to be denser than sea water form in the Minas Basin of the Bay of Fundy. Timing of block formation and block composition were monitored to improve understanding of the potential threat to tidal power generators posed by collision with blocks. Large blocks are produced from ice cliffs that form when anchored ice obstructs tidal channels and decreases flow speed. Decreased flow causes channel cross-sectional area to decrease. In 2012 cross-sectional area of the Kennetcook River decreased by 28% due to formation of ice cliffs. Large ice blocks separated from the cliffs during the two spring tides following the maximum change in cumulative negative degree hours in the atmosphere. Ten percent of sampled ice blocks were denser than freshwater. Four of twelve ice cores collected from the ice cliffs along the Kennetcook contained enough sediment to become denser than seawater.

SEASONAL CONTROL OF BIOFILMS ON SEDIMENT EROSION FROM AN INTERTIDAL MUD FLAT IN KINGSPORT, NS

Jessica Carrière-Garwood and Paul Hill

Department of Oceanography, Dalhousie University, NS

(jessica.cg@dal.ca)

Understanding sediment transport and supply in the Bay of Fundy is crucial to assess the effect tidal turbines will have on coastlines, as well as the threats suspended sediment may present. Ongoing research in the Minas Basin has identified seasonal cycles in the total suspended sediment mass. Models can reproduce the seasonal signal by altering the erosion rate of sediment in summer versus winter, but this hypothesized mechanism has not been tested. This research focuses on the seasonal effects of biofilms on sediment erosion from an intertidal mud flat in Kingsport, NS. Biofilms are thin microalgal mats found at the sediment surface, and they have been shown in other research to influence erosion rates. From April through November 2012, sediment cores were collected biweekly, and a Gust microcosm was used to simulate natural erosion at the sediment surface of the cores. For every collection day, half of the eroded cores remained untreated to assess the natural erosion behaviour of the mud flat. The other half of the eroded cores was treated with bleach to destroy the natural biofilm. By comparing properties of the sediment eroded from each set of cores, the effects of biofilms on erosion were inferred. Results show that, without biofilm, mud flats display a similar erosion behaviour throughout the sampled seasons, and that differences between collection dates can be explained by biofilms and other biological factors.

MODELING THE IMPACT OF LARGE-SCALE TIDAL POWER ON SEDIMENT TEXTURE IN THE BAY OF FUNDY

Shaun Gelati and Paul S. Hill

Department of Oceanography, Dalhousie University, Halifax, NS

(paul.hill@dal.ca)

The output of a 3-D ocean circulation model and information on nearly 10,000 sediment samples are used to examine the extent to which a model of ocean currents can be used to predict seabed sediment texture in the Bay of Fundy and Gulf of Maine. It is found that sediment texture is generally closer to equilibrium with maximum tidal bed shear stress in the Gulf of Maine than in the Bay of Fundy. In the Bay of Fundy, competent mean grain sizes are generally coarser than observed mean grain sizes, and further interpretation suggests that sediment supply has a dominant influence on texture. Furthermore, the impact on texture is predicted for two tidal power development scenarios in the Minas Passage (Hasegawa *et al.*, 2011). For a 2.0 GW power scenario, a sediment fining is predicted in parts of Minas Passage, although the impact should be small as supply dominates texture. Further research is needed to quantify with more precision the potential impact of tidal power development on texture, especially in the Bay of Fundy.

Hasegawa, D., J. Sheng, D. Greenberg, and K. Thompson, Far-field effects of tidal energy extraction in the Minas Passage on tidal circulation in the Bay of Fundy and Gulf of Maine using a nested-grid coastal circulation model, *Ocean Dynamics*, 61, 1845–1868, 2011.

RIDING THE TIDE IS NO BORE: TEMPORAL AND SPATIAL MOVEMENT PATTERNS OF STRIPED BASS IN THE MINAS PASSAGE, BAY OF FUNDY

Freya Keyser¹, Anna M. Redden^{1,2}, and Jeremy Broome¹

¹Acadia Centre for Estuarine Research, Acadia University, NS

²Acadia Tidal Energy Institute, Acadia University, NS

(097882k@acadiau.ca)

The Bay of Fundy's Minas Passage (5 km wide) is currently the site for in-stream tidal energy turbine testing, but is also a passageway for important migratory fish species. Among these is an endangered striped bass (*Morone saxatilis*) population. The objectives of this project were to determine the movement patterns of sub-adult and adult striped bass within the passage, and to assess the potential risk of interaction with tidal energy turbines. Transmitter-tagged striped bass (20 adults and 20 sub-adults) were tracked using 29 bottom-moored VEMCO acoustic receivers. Receivers traversed both sides of the passage and the turbine test area. All recovered receivers (n=27) logged valid detections, with the highest number of detections occurring in July. Of the 40 striped bass tagged, 25 were detected, with more adults detected (75%) than sub-adults (50%). Adult fish were detected throughout the water column, while sub-adults were detected only in the top 25 m (above turbine height). Fifteen striped bass (mostly adults) moved back and forth through the passage with swimming speeds between 1.20 and 3.56 m/s. Fish were detected more often at night than during the day. Detection frequency was higher during neap tidal cycles than during spring tidal cycles and was negatively correlated with current speed. Individual striped bass were shown to make multiple crossings of the Minas Passage during summer and many passed through the turbine test site at turbine hub height. The ability of striped bass to detect and avoid tidal turbines when travelling at high speed remains unknown.

ELECTRICAL DESIGN CONSIDERATIONS OF SUBMARINE POWER CABLES

Aaron M. MacNeill¹, Mohamed E. El-Hawary¹ and Sue Molloy²

¹ Department of Electrical and Computer Engineering, Dalhousie University, Nova Scotia

² Glas Ocean Engineering, Halifax, Nova Scotia

(aaron.macneill@dal.ca)

Introduction

This presentation highlights results of a recently completed study conducted at Dalhousie's Group on Marine Energy Research (GMER) based in the Department of Electrical and Computer Engineering prepared for CanmetENERGY, Natural Resources Canada, under the Program for Integrated Renewable Electricity Systems allocated by the Program of Energy Research and Development (PERD) POL 5.1 Marine Renewable Energy.

The study investigated subsea electrical cable properties that influence the transfer of electric power from a marine renewable energy installation to shore. It is anticipated that there will be measureable losses as the power is transmitted from the subsea turbines, for example, to the on-shore substation. The conditioning required to minimize power losses and the impact of cable length on these losses have not been fully explored to date.

Line Parameters

A comparison of traditional overhead transmission lines with expected subsea cable properties showed that power compensation must be made while transmitting electrical energy via subsea cables to ensure that minimum power loss and power quality degradation occurs. The study treated a comprehensive set of currently commercially available single- and three-core submarine power cables for alternating current (AC) applications (ABB, 2010). The typical simplified geometries for these cables can be seen below in Figure 1.

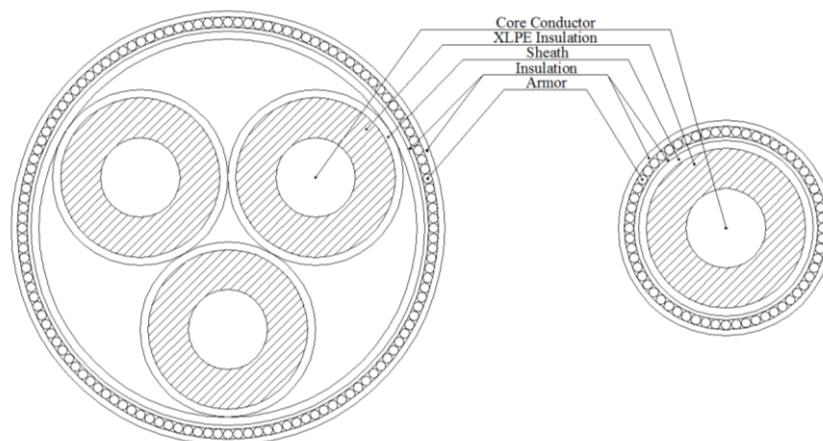

Figure 1. Cable Geometries

In reality the layering of these cables is more complex. This layering complexity can, however, be simplified to the form seen in Figure 1. This is done by comparing the electrical properties of the various layers (MacNeill *et al.*, 2013). This allows combining similar layers into an equivalent layer. Starting from the fundamental principles of electromagnetic field theory, electric line parameters can be estimated for these cables (Schelkunoff, 1934; Bianchi and Luoni, 1976; Sadiku 2007). These electric line parameters are defined as follows:

- Series Resistance, R (related to energy dissipation by the cable).
- Series Inductance, L (related to magnetic energy storage in the cable).
- Shunt Capacitance, C (related to electric energy storage in the cable).
- Shunt Conductance, G (related to energy dissipation by the cable).

These line parameters are solely dependent on the geometric configurations and material characteristics of the cable. The estimation of these line parameters is critical to being able to evaluate the performance of a marine energy installation, and how it will interact when connected to the distribution power system.

Performance Evaluation

A transmission line can be modeled by a two-port network. The transmission line has an input generation that is specified (voltage and current) and based on the line parameters (R , L , C , and G). The output (voltage and current) can be estimated by knowing the defined input and the line parameters. Figure 2 below provides an example of a two-port network that is used for modeling transmission lines.

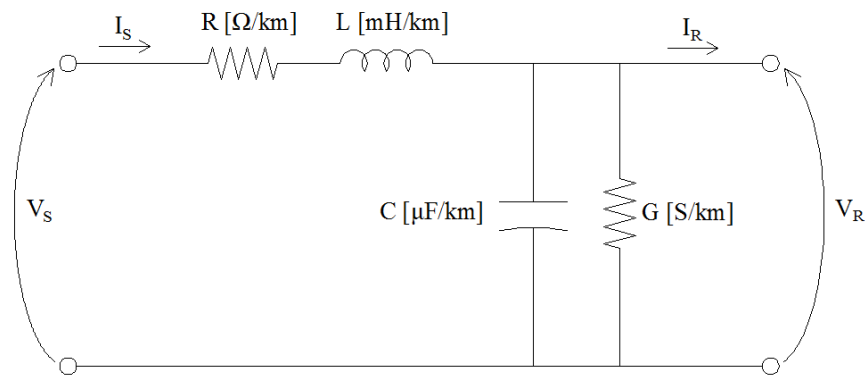

Figure 2. Two-Port Network Model

This two-port network model allows the determination of transient and steady state performance characteristics of a transmission line. These performance characteristics are used in system planning and design of offshore interconnections in marine energy applications. The performance indices for evaluating a cable's steady state performance are as follows (El-Hawary, 1995; MacNeill *et al.*, 2013):

- Onshore received voltage (allows for determination of how to synchronize the generator to the grid for AC applications).

- Onshore received power and reactive power (quality of the received power, determines if reactive power compensation is required). The received power is the power that is useable by a consumer, the reactive power is the energy stored in the inductance and capacitance of a transmission line in order to allow the power to flow to consumers.
- Onshore voltage regulation (how stable the voltage is as the load varies).
- Transmission line efficiency (energy dissipation by the cable).

These performance indices provide a means to evaluate the quality of the power being provided to the distribution substation and whether conditioning will be required. Conditioning improves the quality of the received power such that it is acceptable for consumer use. In addition to the steady state performance of the cable, the transient performance must be evaluated. The transient performance can be quantified by the following indices (El-Hawary, 1995; MacNeill *et al.*, 2013):

- Oscillation damping (determines how quickly energy fluctuations cease).
- Peak voltage overshoot (determines the highest receiving end voltage).
- Inrush current to the cable (determines current required to charge the transmission line).

These transient performance indices allow for analyzing the electrical stresses incurred by an offshore generator when switching or fault actions occur. The frequency response of the cable must also be evaluated to observe how potential power converter harmonics will propagate naturally through the cable. Harmonics are frequencies that are different from the AC voltage frequency, 60Hz.

The two-port network that is used for modeling transmission lines uses incremental lengths of the transmission line shown in Figure 2 (a large number of these transmission lines in cascade) as opposed to using lumped components. This provides a more accurate representation of the transmission line. The sending end voltage and current, denoted V_S and I_S , respectively, are defined by the generator's output. The receiving end voltage and current, denoted V_R and I_R , respectively, can be found from the developed two-port network equations (El-Hawary, 1995). These two port network equations are as follows:

$$\begin{aligned} V_R &= DV_S - BI_S \\ I_R &= AI_S - CV_S \end{aligned}$$

Where,

$$A = D = \cosh(\Gamma\ell), B = Z_0 \sinh(\Gamma\ell), \text{ and } C = \frac{1}{Z_0} \sinh(\Gamma\ell)$$

Where,

$$\Gamma = \sqrt{(R + j\omega L)(G + j\omega C)}, Z_0 = \sqrt{\frac{(R + j\omega L)}{(G + j\omega C)}}$$

In the above equations, the line parameters (R, L, G, and C) are in per unit length form. The length of the transmission line is denoted by ℓ . From these equations, the steady state performance of the cable can be evaluated. The transient state performance can be approximated from the circuit shown below in Figure 3.

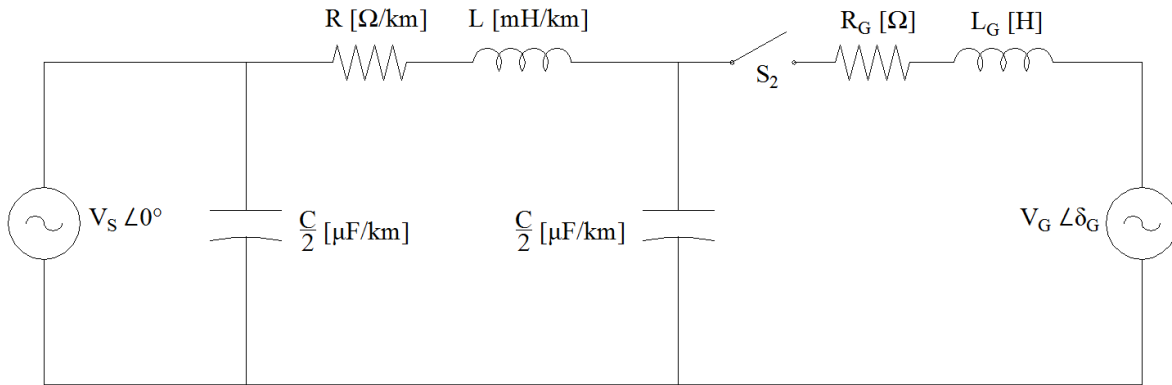

Figure 3. Transient Network Model

The transient performance of this cable can be evaluated from analyzing the differential equations governing this network. The transient analysis requires initial conditions of the circuit at the time when switch S_2 is closed (Greenwood, 1971). These initial conditions (current through the inductor and voltage across the capacitor) can be found from the steady state performance of the system.

Results

A sample simulation has been performed to show the difference between the various types of submarine cables and an equivalent set of overhead transmission lines. Figures 4 through 9 show the simulation results for the performance indices for the cables.

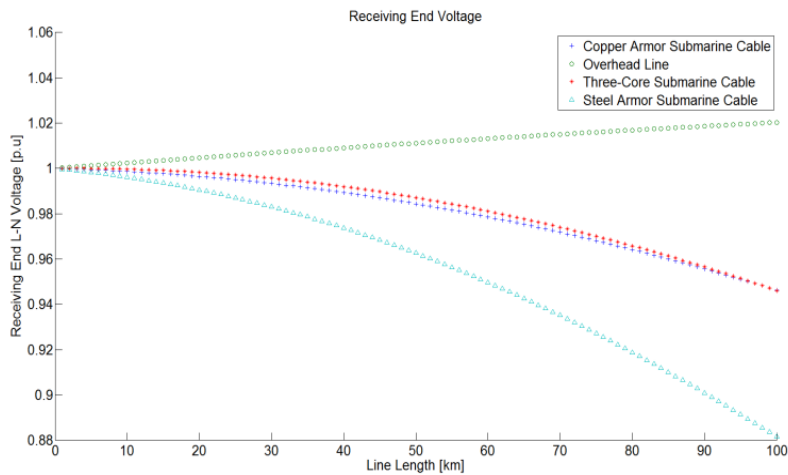

Figure 4. Receiving End Voltage

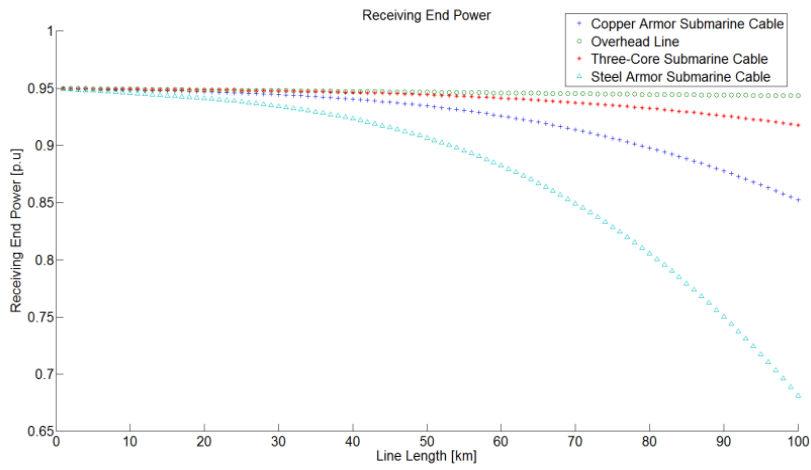

Figure 5. Receiving End Power

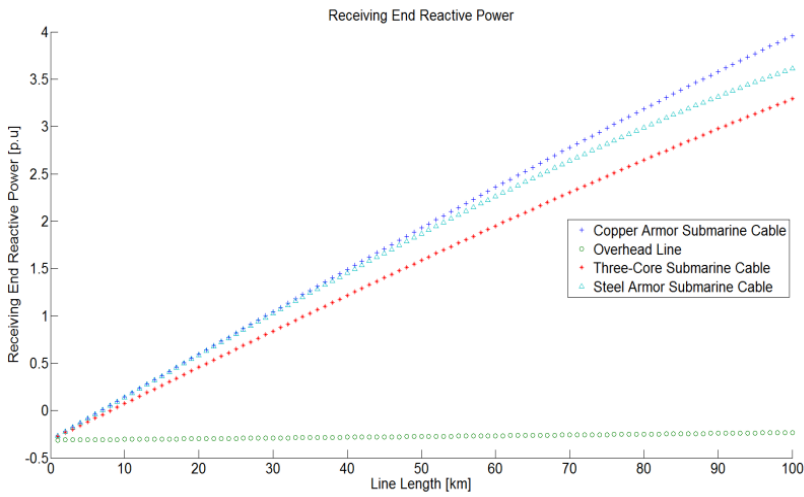

Figure 6. Receiving End Reactive Power

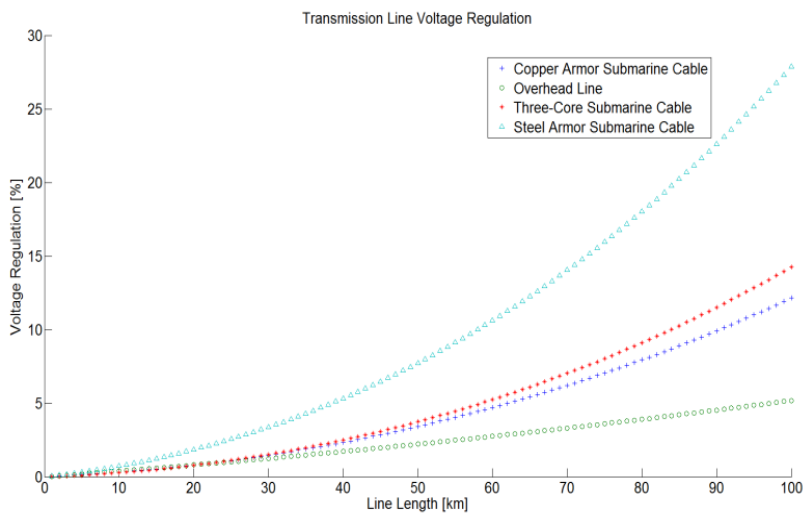

Figure 7. Receiving End Voltage Regulation

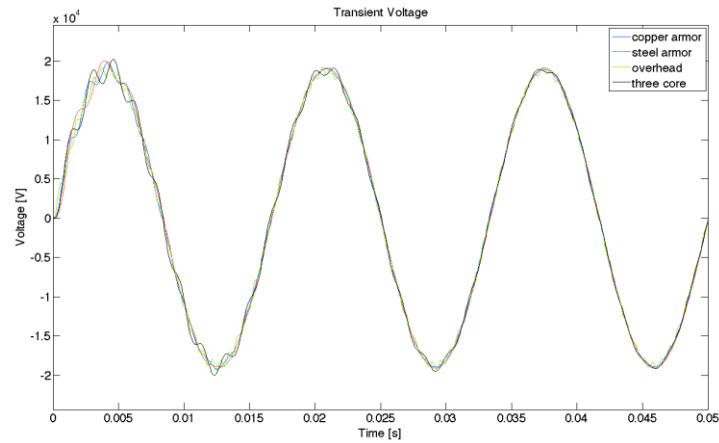

Figure 8. Transient Receiving End Voltage, 10km Line

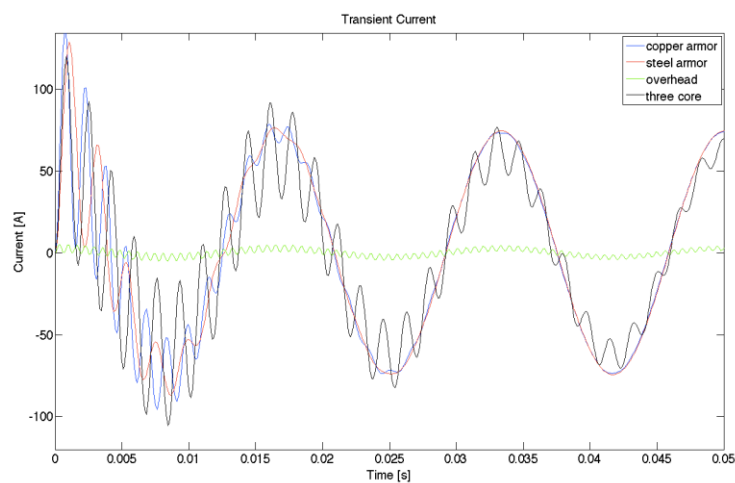

Figure 9. Transient Generator Current, 10km Line

The study has shown that submarine cables have unique electrical characteristics that need to be taken into account when specifying the transmission of power from marine energy converters. The significant differences between submarine cables and overhead transmission lines are listed below:

- Submarine cables provide considerable reactive power to the system due to their large capacitance. Reactive power refers to actual power that shuttles back and forth to charge inductance and capacitance.
- In the case where the sending end power factor is lagging, there is a line length where the receiving end power factor could be close to unity.
- Submarine cables are not as efficient as overhead lines for similar transmission distance.
- The receiving end voltage magnitude fluctuates (rises, maximizes, and then decreases) in submarine cables; for overhead lines the voltage tends to continually rise.
- The voltage regulation for submarine cables is not as stable as for overhead transmission lines.

One of the advantages of a submarine cable is that it could feed the reactive power demand of the electric power generators (induction and permanent magnet generators) that are commonly used in marine energy converters. This balancing of reactive power demand from the generator and production from the cable means that there is an enhanced quality of power reaching shore. The disadvantage is the possibility of introducing resonances in the transmission line. Resonances introduce high levels of voltage that can be detrimental to the integrity of many system components.

The findings from this evaluation could assist in the designing of submarine cable geometry to improve electrical characteristics; hence improving the quality of electric power transmission to shore and contributing to overall reliability of marine energy electric generation.

Design Considerations

There are many design considerations involved in choosing an underwater cable that is appropriate for use in an offshore power installation. Some are as follows (Worzyk, 2009; MacNeill 2012):

- Thermal limitations in ampacity of the cable.
- Forces applied to lay the cable in the water/tidal currents, electromechanical forces between the conductors under transient conditions, and external sources of damage. These are mechanical forces seen by underwater power cables.
 - The armour material choice and thickness affects the efficiency of the cable.
- The choice of using AC or DC transmission.
 - DC generators are typically more expensive than AC generators.
 - DC will require power converters.
 - Introduction of harmonics.
 - AC will potentially require reactive power support.
 - Design of a cable's insulation thickness could potentially provide the reactive power support for an induction machine.
 - Harmonic resonances are produced.
 - DC allows for higher cable ampacity.
 - AC allows for large Ferranti effect.
 - Voltage swells at the receiving end of the transmission line.
 - DC only requires two cables, AC requires three.
 - DC would allow easier interconnection of multiple offshore power installations.
- The choice of cable configuration.
 - Single-core cables can sustain higher voltage than multi-core cables.
 - Single-core cables allow for better heat dissipation.

- More underwater trenches required for single-core cable applications.
- Three-core cables do not allow for cheap redundancy if a single core fails.
- Steel armour causes diminished cable efficiency in single-core cables.
- Magnetic field in the environment surrounding a three-core cable diminishes faster than for a single-core cable.

Coupled with the economics behind these design considerations and the performance characteristics, the best choice for a cabling system to be used for an offshore marine energy site or site interconnections can be made.

Conclusion

From this study it is seen that the choice of an underwater power cable is an important aspect in the design of a marine energy application. Taking into account all of the design considerations and economic implications, the best solution for how to transmit the electrical energy back to shore, or to interconnect several offshore installations can be developed. For smaller scale power production, for example in the COMFIT program, or larger scale installations such as the Maritime Link this can provide valuable information as to what the best power solutions may be for transmitting the electrical energy.

References

- ABB [2010], "XLPE Submarine Cable Systems Attachment to XLPE Land Cable Systems – User's Guide", ABB
- Bianchi, G., Luoni, G. [1976], "Induced Currents and Losses in Single-Core Submarine Cables", IEEE Transactions on Power Apparatus and Systems, Vol. PAS-95, No. 1
- El-Hawary, M.E. [1995], "Electrical Power Systems Design and Analysis", IEEE Press, New York, NY
- Greenwood, A. [1971], "Electrical Transients in Power Systems", Wiley-Interscience, US
- MacNeill, A.M. [2012], "Submarine Power Cable Transmission Line Parameters and Performance", MASc Thesis, Department of Electrical and Computer Engineering, Dalhousie University, Halifax, NS
- MacNeill, A.M., El-Hawary, M.E., Molloy, S. [2013], "Submarine Power Cable Electrical Performance Evaluation for Marine Energy Applications", The Journal of Ocean Technology, Vol.8, No.1
- Sadiku, M.N.O. [2007], "Elements of Electromagnetics Fourth Edition", Oxford University Press, New York, NY
- Schelkunoff, S.A. [1934], "The Electromagnetic Theory of Coaxial Transmission Lines and Cylindrical Shields", Bell System Technical Journal, Vol. 13, pp. 532-578
- Worzyk, T. [2009], "Submarine Power Cables Design, Installation, Repair, Environmental Aspects", Springer, Heidelberg, Berlin

ACOUSTIC DETECTION RANGES FOR MARINE MAMMAL MONITORING AT A TIDAL TURBINE SITE: GRAND PASSAGE, NS.

Chloe Malinka¹, Alex E. Hay², Richard A. Cheel² and Mark Wood³

¹Dalhousie University, NS.

²Ocean Acoustics Lab, Department of Oceanography, Dalhousie University, NS

³Ocean Sonics Ltd., Great Village, NS

(chloe.malinka@DAL.CA)

Passive Acoustic Monitoring (PAM) for marine mammals at tidal energy developments requires an understanding of site-specific acoustic detection ranges. Since underwater sound is used as a tool for detecting marine mammal presence via their vocalizations, sounds mimicking those of marine mammals were projected to assess the feasibility of a PAM system at a proposed small-scale (<2 MW) tidal energy site in Grand Passage, NS. Consecutive sweeps were transmitted with an Ocean Sonics underwater projector (*icTalk*) from a rigid inflatable boat as it drifted over a moored Ocean Sonics hydrophone (*icListen*) in July 2012. A Nortek Vector velocity sensor co-located with the hydrophone measured the flow to determine the hydrophone's effective detection range over the phase of the tide. The conditions under which the projected sounds were detectable will be presented. Furthermore, the naturally occurring ambient noise in high-flow environments imposes rather severe constraints on detection limits. Noise reduction techniques were field-tested in an attempt to extend acoustic detection ranges. Ambient noise levels were measured with a drifting hydrophone to establish baseline acoustic conditions prior to turbine installation, relevant to the tidal project's environmental assessment process. This work will contribute to the future monitoring of marine mammal presence in the vicinity.

MEASUREMENTS AND SIMULATIONS OF THE FLOW IN DIGBY NECK PASSAGES

Justine McMillan¹, Alex Hay¹, Richard Karsten², Doug Schillinger¹ and Greg Trowse³

¹Dalhousie University, Halifax, NS

²Acadia University, Wolfville, NS

³Fundy Tidal Inc., Westport, NS

(justine.mcmillan@dal.ca)

The development of small-scale tidal power is progressing in the lower Bay of Fundy. Three passages -- Grand Passage, Petit Passage and Digby Gut -- are all approximately 1 km wide and 4 km long; however, the dynamics within each passage are highly dependent on the local bathymetry and coastline. In particular, two passages are open-ended, while one is essentially closed at one end. In an effort to study these dynamics and to estimate the tidal power potential, a resource assessment of each passage was completed in 2012 using arrays of acoustic Doppler current profilers (ADCPs) and a high-resolution, unstructured grid, numerical model.

Unlike many resource assessments which utilize a single ADCP at a site of interest, in this study, five ADCPs were deployed simultaneously in each passage for approximately one month. The ADCPs were positioned predominantly in an along-channel configuration; however, in Grand Passage, a cross-channel configuration was implemented in an effort to test the model's ability to capture the highly variable flow past an island.

In this poster, the characteristics of the flow as measured by the ADCPs and as predicted by the model will be compared. The results will focus on the speed, direction and power density of the flow, as well as on estimates of the frictional stress exerted by the flow on the sea floor. For each passage, the observed dynamics on both the tidal and supra-tidal timescales will be discussed and the performance of a typical Tidal-Energy Converter will be estimated.

SEASONAL MIGRATION OF THE AMERICAN LOBSTER, *HOMARUS AMERICANUS*, THROUGH THE FORCE TIDAL TURBINE TEST SITE AND MINAS PASSAGE, BAY OF FUNDY

Kaycee Morrison¹, Jeremy Broome² and Anna Redden^{1,2,3}

¹ Department of Biology, Acadia University, Wolfville, NS

² Acadia Centre for Estuarine Research, Acadia University, Wolfville, NS

³ Acadia Tidal Energy Institute, Acadia University, Wolfville, NS

(kayceemorrison@gmail.com)

The American lobster commercial fishery is Canada's most valuable seafood export, with a significant portion of the catch sourced from the Bay of Fundy. According to local fishers, lobster populations within LFA 35 in the upper Bay of Fundy undergo seasonal migration, with movements into the Minas Basin in spring and outwards in the late fall, via the Minas Passage. Anecdotal information indicates that temperature is the dominant migratory cue. The Fundy Ocean Research Centre for Energy (FORCE) tidal turbine test site (est. 2009) is located within the Minas Passage and studies to assess the potential impacts on marine biota have commenced. The primary objective of our study was to use Vemco acoustic tracking technology to determine use of the Minas Passage and FORCE test site as a migration corridor. In November 2011, 85 adult American lobsters from the Minas Basin were fitted with V13 acoustic transmitters and numbered disc tags, and released near the site of capture. Twenty-six bottom-mounted receivers spanned the width of the Minas Passage in two arrays, east and west of the FORCE site; another three receivers were moored in the FORCE lease area. From fall 2011 to summer 2012, a total of 98,330 tag transmissions from 31 lobsters were recorded. Of these lobsters, 74% were detected on receivers in the northern half of the Minas Passage, including eight lobsters detected on receivers within the FORCE test site. Mean rate of movement in fall was 0.32 km/day (\pm 0.34 km/day). During spring 2012, 10 tagged lobsters were detected in Minas Passage (7 re-detects, 3 new detections), presumably returning to the Minas Basin. Movement between multiple arrays was shown for one tagged lobster, which had a mean travel rate of 0.35 km/day (\pm 0.08 km/day). Additional lobsters tagged in late 2012 will contribute to the assessment of movements during the winter months and will test the hypothesis that lobsters swim in the Minas Passage during very high flow periods.

BOTTOM SUBSTRATE AND ASSOCIATED EPIFAUNA AT THE FORCE TIDAL TURBINE TEST SITE, MINAS PASSAGE, BAY OF FUNDY

Kaycee Morrison¹, Patrick Stewart² and Anna Redden^{1,3}

¹ Department of Biology, Acadia University, Wolfville, NS

² Envirosphere Consultants Ltd., Windsor, NS

³ Acadia Centre for Estuarine Research, Acadia University, Wolfville, NS

(kayceemorrison@gmail.com)

The crown lease area of the Fundy Ocean Research Centre for Energy (FORCE), along the north shore of the Minas Passage, is characterized by a glacially influenced sedimentary basin, interspersed with volcanic bedrock subject to considerable scouring. This study examines the seafloor and benthic habitat of the FORCE lease area and describes features on which tidal energy infrastructure will be installed. The study presents baseline data that will be useful in addressing potential environmental effects of demonstrating tidal energy technologies (e.g. turbines, moorings, cables). The benthic community of three berth areas and their associated cable routes was examined via qualitative and quantitative analyses of videographic material collected in 2008-2009. ImageJ photo software was used to analyze 1197 frames for geophysical features (substrate type, size) and abundance (or percent cover) of macrobiota. Relationships between biota and substrate type were examined. Although biodiversity in this high flow environment was low, the percent cover of *Halichondria panicea*, the yellow breadcrumb sponge, was often high and positively correlated with degree of exposed bedrock. Other taxa present, but in low numbers, include two species of seastar, white sponge, and anemones. Macroalgae featured prominently in the shallow regions (<10m) of the cable routes. The biological and physical features of the seafloor were mapped to better inform FORCE and tidal energy project developers about the characteristics of their berths. This study provides mesoscale baseline data for use in the determination of environmental impacts on and of subsea cables and mooring structures.

HIGH RESOLUTION NUMERICAL MODELLING OF DIGBY NECK PASSAGES

Mitchell O’Flaherty-Sproul¹, Richard Karsten¹, Justine McMillan², Greg Trowse³ and Alex Hay²

¹ Acadia University

² Dalhousie University

³ Fundy Tidal Inc.

(073208o@acadiu.ca)

Fundy Tidal Inc. has been awarded Community Feed-in-Tariffs for Grand Passage, Petit Passage and Digby Gut, which all have high energy flows that are close to landfall. The goal of this research project was to produce a high-resolution numerical model of the passages that could be used for site selection and characterization.

We use FVCOM with an unstructured grid that has a resolution of roughly 15m in each passage. High-resolution bathymetry was gathered and combined with accurate coastline data to produce a very accurate grid. Both 2D and 3D simulations are run for time periods of a few days to 40 days. The model results were validated against data collected from multiple Acoustic Doppler Current Profiler (ADCP) deployments that were part of the Southwest Nova Scotia Tidal Energy Resource Assessment. The model does an excellent job of predicting tidal elevation and basic tidal flow. It also predicts intra-tidal fluctuations in the flow at the correct locations and times. However, the magnitude of the fluctuations is generally too large, which can drastically increase the maximum speed measured at a site. In Digby Gut, where the bathymetry was of lower quality, the simulated tidal currents did not compare as well to the gathered data.

The project has illustrated that high-resolution numerical modelling can be an effective tool for site characterization – for example the spatial characteristics of flow fluctuations can be connected to bathymetric features. However, ensuring that fluctuations are modelled correctly and quantifying the fluctuations for resource assessment and site characterization are outstanding research.

THE COMMOTION IN THE OCEAN – DETECTING HARBOUR PORPOISES (*PHOCOENA PHOCOENA*) AT THE FORCE TURBINE TEST SITE IN THE MINAS PASSAGE, BAY OF FUNDY

Peter Porskamp¹, Jeremy Broome², Jason Wood³ and Anna Redden^{1,2}

¹Department of Biology, Acadia University, Wolfville, NS

²Acadia Centre for Estuarine Research, Acadia University, Wolfville, NS

³Sea Mammal Research Unit LLC, Friday Harbour, WA

(099111p@acadiau.ca)

Tidal power development sites introduce potential risks to marine mammals. Our project was focused on an assessment of harbour porpoise (*Phocoena phocoena*) activity at the Fundy Ocean Research Centre for Energy (FORCE) turbine test site in the Minas Passage. In this location, the maximum tidal range is 13 m; surface current speeds peak at about 6 m/s. The study also involved a comparison of the performance of two hydrophone types, the Chelonia Porpoise Detector (C-POD) and the icListenHF (Ocean Sonics Ltd). Diel, tidal and lunar patterns in porpoise activity were examined during the entire month of August 2012. The data contribute to an assessment of the potential risks of turbine-porpoise interaction at the FORCE site. Two C-PODs and one icListenHF were bottom moored and co-located in the FORCE test area. Detection positive minutes (DPMs, click train detection within each minute) were used to indicate porpoise presence. The icListenHF recorded approximately 10x more DPMs than the C-PODs, reflecting a listening volume for the icListenHF that is about 11x that of a C-POD. There were more DPMs at night than during the day, and more DPMs on neap tides than spring tides. Ambient noise levels, which were highest during a spring tide and higher during flood periods than during ebb periods, resulted in some lost detection time. At very high current speeds, the performance of both hydrophone types was affected by noise interference, presumably due to bedload transport and likely also due to noise generated by mooring chain. This study and a hydrophone drift study planned for spring 2013 will help inform the design of future marine mammal impact assessment studies at high flow development sites in the region.

SEASONAL SEDIMENTATION AND HYDRODYNAMICS IN A BAY OF FUNDY TIDAL CREEK AND SALT MARSH SYSTEM

Emma Poirier¹, Danika van Proosdij¹ and Timothy Milligan²

¹Department of Geography, Saint Mary's University, NS

²Fisheries and Oceans Canada, Bedford Institute of Oceanography, Dartmouth, NS

(emmapoirier@hotmail.com)

With the goal of characterizing the far field effects of tidal energy extraction on Bay of Fundy intertidal zones sedimentation, hydrodynamics and sedimentation rates were measured in a macrotidal creek and salt marsh system. Sediment deposition, current velocities and suspended sediment concentrations were collected over different seasonal conditions from May 2012 to March 2013. The data were collected in a transect from the creek to the marsh surface to characterize the physical processes impacting sediment deposition in this system. Three high resolution elevation surveys were conducted to characterize the change in topography of the channel. During rain events, sediment deposition in the creek increased, but the sediment deposition on the marsh was not affected. Sediment deposition on the marsh bank, edge and surface increased with higher sediment availability during November and January. Suspended sediment concentration, along with sediment deposition, showed a decreasing trend from the creek to the marsh surface. Concentrations in the creek clearly varied by season, being higher during winter conditions, but concentrations on the marsh remained more uniform throughout seasons. Velocities on the marsh were highest on the marsh edge and lowest on the marsh bank. On the marsh surface and edge, velocities showed tidal symmetry while on the bank flood dominance existed. These data will be used to feed a high resolution sediment transport model in a companion project, and also serves to strengthen relationships between sediment deposition in a tidal creek and salt marsh with the factors which are influencing it.

INTRODUCING A DYNAMIC PENETROMETER FOR GEOTECHNICAL TIDAL ENERGY CONVERTER SITE ASSESSMENT AND MONITORING

Nina Stark¹, Alex E. Hay¹, Justine M. McMillan¹, Greg Trowse² and Achim Kopf³

¹ Department of Oceanography, Dalhousie University, Halifax, NS

² Fundy Tidal Inc., Westport, NS

³ MARUM, University of Bremen, Bremen, Germany

(nina@phys.ocean.dal.ca)

Cone Penetrometer Testing (CPT) using engine-driven, quasi-static offshore devices is required to gather in-situ geotechnical information of the upper meters of the seafloor. Such instruments allow the determination of sediment strength and pore pressure, but are sensitive with regard to the presence of rocky surfaces or cobbles, are deployable under mild hydrodynamic conditions only and are expensive. Recently, the small-scale dynamic penetrometer *Nimrod* was tested for early-stage geotechnical probing in Grand Passage, NS, a proposed tidal energy converter site in the Bay of Fundy. The probe was developed for rapid geotechnical characterization of surficial seafloor sediments and estimation of sediment dynamics in subaqueous areas of difficult access (strong hydrodynamics, close to offshore structures, etc.). The results from two surveys carried out with *Nimrod* in 2012 indicate that areas of different geotechnical characteristics corresponding to variations in grain size, geomorphology and bathymetry were mapped successfully, and the amount of poorly consolidated surficial sediment available for sediment transport was assessed. Areas of higher sediment mobility were identified and correlated to the existence of large-scale bedforms. The technique proved to be suitable for early-stage geotechnical surveying and the investigation of ongoing sediment dynamics relevant for the installation of tidal energy converters. It also potentially represents a cost- and time-efficient method to monitor changes in surficial sediment texture and sediment dynamics under different hydrodynamic conditions, and for the investigation of scour and potential weak layer development in the wake of tidal energy converters post-installation.

OBSERVATIONS OF HARBOUR PORPOISE (*PHOCOENA PHOCOENA*) AT THE FUNDY TIDAL ENERGY DEMONSTRATION SITE, MINAS PASSAGE, NOVA SCOTIA, 2009-2012

Patrick Stewart¹ and Fulton Lavender²

¹Envirosphere Consultants Limited, Windsor, NS

²Halifax, NS

(enviroco@ns.sympatico.ca)

Harbour Porpoise (*Phocoena phocoena*) are small cetaceans found on north temperate continental shelves of the north Pacific and Atlantic, and in Eastern North America from North Carolina to 70 ° N, with sub populations in the Bay of Fundy-Gulf of Maine, Gulf of St. Lawrence and Newfoundland-Labrador. Populations in the Bay of Fundy-Gulf of Maine system are about 90,000 but the current population trend is unknown. The species is listed as threatened under the Canadian *Species at Risk Act*. Harbour Porpoise are commonly seen in the inner Bay of Fundy, but records of its local distribution and abundance are scarce. It was observed during baseline environmental monitoring surveys for marine mammals and seabirds conducted in Minas Basin, Minas Passage and Minas Channel from 2009 to 2012 for the FORCE (Fundy Ocean Research Centre for Energy) Fundy Tidal Energy Demonstration site, and was a relatively common visitor to the demonstration site during shore-based seabird surveys in 2010-2012. The species occurred from early March to late-November in most survey periods (winter surveys were not conducted) with highest abundances observed in March 2011 and July-August 2012, thought to coincide with movements of fish, particularly spring spawning herring, and other forage species (e.g. squid). Individuals typically occurred singly or in groups of 2-3, but groups of 5-8 also occurred, moving with the outgoing tide and occasionally feeding (circling behaviour); however, more-detailed behavioural observations were not made. Movements and behaviour on the rising tide, as well as habitat utilization throughout the tidal cycle in the area are not known.

**FUNDY TIDAL ENERGY DEMONSTRATION SITE, SEABIRD SURVEYS—MINAS PASSAGE,
2008-2012**

Patrick L. Stewart¹, Fulton L. Lavender² and Heather A. Levy¹

¹Envirosphere Consultants Limited, Windsor, NS

²Halifax, NS

(enviroco@ns.sympatico.ca)

Seabirds are important in the marine ecosystem of the Bay of Fundy and, in the context of tidal power development, they have the potential to interact with tidal turbines and be affected by associated activities. The location of the tidal energy demonstration site on the shore of the Minas Passage—the location of the highest tidal currents—is known to support various seabird and waterfowl species common to coastal environments in Atlantic Canada. As part of the Environmental Effects Monitoring (EEM) Program for the site, the Fundy Ocean Research Centre for Energy (FORCE) has carried out baseline and first-, second-, third- and fourth-year monitoring studies in 2008 and 2009-2012, respectively, on bird distribution and abundance to allow assessment of impacts in the vicinity of the tidal demonstration site. Shore-based coverage of seabird distributions at the site was obtained through most of the year, vessel survey coverage in summer for four years and a comparison between shore- and vessel-surveys in summer 2012 were also made. Overall, 47 species of water-associated birds have been identified from the Minas Basin, Minas Passage and Minas Channel area. Apart from species commonly occurring in Nova Scotia waters, the surveys identified some accidental species such as Northern Fulmar (a subarctic species) as well as noted distribution shifts of Pacific Loon—a species, which was thought to be rare in Atlantic Canada, but which has been regularly seen at the site during the Spring and Fall migration and in summer. An overview of all seabird vessel and shore-based survey data will be presented.

SEASONAL VARIABILITY OF TOTAL SUSPENDED MATTER IN MINAS BASIN, BAY OF FUNDY

Jing Tao¹, Paul S. Hill¹ and Ryan P. Mulligan²

¹Dalhousie University, NS

²Queen's University, ON

(jing.tao@dal.ca)

Minas Basin, at the eastern end of the Bay of Fundy in Nova Scotia, is a large macro-tidal estuary. Strong currents associated with the extremely large tidal water level range could potentially provide a source of renewable tidal energy but are a fundamental part of the Bay of Fundy ecosystem. Significant extraction of tidal energy could lead to local and far field changes in the tidal regime and sediment dynamics. Observations of total suspended matter (TSM) concentrations were derived from ocean colour imagery (MERIS data) in Minas Basin from May 2008 to July 2011. Analysis of time series of TSM in 1-km-square pixel boxes throughout the Basin revealed an annual cycle in TSM in most parts of the Basin. Larger TSM was observed in mid-winter (Feb. - Mar.), and smaller TSM characterized mid-summer (Jul. - Aug.). The largest annual variation occurred in the center of Minas Basin, and the smallest variation occurred in shallow areas. Satellite-derived TSM were compared to predictions using the Delft3D model. Increasing model erosion rate in winter relative to summer was necessary to improve agreement between model and satellite-derived TSM. Relative to satellite-derived estimates, the model overestimated TSM in shallow areas in summer and underestimated it in winter. This discrepancy is likely due to inaccurate satellite-derived TSM in shallow, high concentration areas of the Basin.

ON THE MELT RATE OF SUBMERGED SEDIMENT-LADEN ICE

Greg Trowse and Alex Hay

Dalhousie University, Department of Oceanography

(gtrowse@gmail.com)

Submerged sediment-laden ice blocks that form on the intertidal mud flats of the Minas Basin pose a potential threat to tidal turbines planned for deployment in the Minas Passage. We report on results from laboratory investigations of the melt rate of sediment-laden and sediment-free ice, aimed at determining probable upper limits to the lifetimes of submerged ice blocks in the field.

Laboratory prepared ice blocks of varying sediment content, salinity, and length scale were melted in seawater of different far-field temperatures. The effect of sediment inclusions on melt rate is related to changes in heat supply and heat requirement to melt a unit mass of sediment-laden ice, where the former is affected by the strength of the convective current and the latter by the ice block properties. At small length scales, sediment inclusions decreased melt rate due to cohesion, creating a sediment coating between the convective heat flow and the ice surface with insulating properties, and reducing the sediment concentration of the meltwater turbidity current. Both effects decrease the rate of heat supply to the ice surface. Heat flow increases with length scale to approach that of sediment-free ice such that large sediment-laden ice blocks melt faster than sediment-free ice due to decreased heat requirement.

The model has been used to predict lifetimes of large submerged ice blocks using far-field temperatures representative of seawater in the Minas Basin in February and March. The predicted lifetime of a 5,000 kg freshwater sediment-laden ice block is approximately 115 hours in 1°C seawater.

THE LEVELIZED COST OF ENERGY AND THE IMPORTANCE OF CASH FLOW RISK ANALYSIS

Lisa Visentin

Acadia University

(098572v@acadiau.ca)

The levelized cost of energy calculation (LCOE) is a consensus measure, and industry standard, for comparison of different energy sources, both conventional and renewable. The LCOE calculation allows for comparison of cost, and performance, of various energy sources when differences in scales of operations, financial investment, and/or economic lives exist. The calculation uses the Gordon Growth Model to discount cash flows at the appropriate risk-adjusted cost of capital, in order to determine the breakeven cost of the energy source. The output from the calculation can be seen as the average price energy consumers would need to pay in order for investors and project developers to exactly cover all of the costs needed to produce the energy.

In order to obtain financing to further the development of tidal energy in Nova Scotia, the levelized cost of energy must not only be accurately communicated, but also accurately calculated. The LCOE calculation produces a single-point estimate of the cost of the energy source, based on estimated future expected cash flows. Because cash flows cannot be estimated with precision, there is risk involved. In order to adjust for this risk, it is appropriate to conduct a cash flow risk analysis. A cash flow risk analysis can be conducted in terms of scenario analysis, sensitivity analysis, a Monte Carlo simulation, or a combination of the 3 methods. An overview of the levelized cost of energy calculation will be presented; outlining what is to be included in the calculation, the appropriate discount rate, and the benefits and limitations of the calculation's output. In addition, an explanation of the 3 cash flow risk analysis methods will be given, including the benefits of their use.

7.0 SUMMARIES OF BREAKOUT SESSION DISCUSSIONS

DAY 1 BREAKOUT SESSION THEME

COLLABORATION AND ENGAGEMENT IN TIDAL ENERGY RESEARCH & DEVELOPMENT

The purpose of the workshop format group discussions was to provide symposium participants the opportunity to:

- Open a dialogue on the challenges and opportunities for collaboration and partnerships;
- Brainstorm practical approaches, tools, programs or projects to facilitate multi-institutional, multi-sector, inter-regional and international collaboration and coordination in Research & Development for tidal energy in Nova Scotia.

Symposium delegates were assigned to one of five discussion groups on the following topics:

1. International Opportunities
2. Research Collaboration across Tidal Sites in Nova Scotia (Minas Passage, Digby Neck, Cape Breton)
3. Regional Multi-Sector Collaboration (Academic, Government, Industry)
4. Involvement of Community Stakeholders, Policy Makers and Regulators
5. Coordination of Roles and Responsibilities among Groups and Institutions
6. Engagement and Collaboration with Students in Tidal Energy Research in Nova Scotia

An effort was made to match delegate expertise to the topics, but also to provide an even balance of institutional and sectoral representation across groups.

Following are the summaries of discussions held by six breakout session groups.

Group 1 – International Opportunities

Group Lead: Dan MacDonald, University of Massachusetts Dartmouth

This breakout group was encouraged to open a dialogue on the potential and challenges of international collaborations and to brainstorm on opportunities, approaches and tools.

The keys points resulting from the group discussion are as follows:

What areas in research should be the first priorities for collaborative efforts across the U.S. – Canada border and/or internationally? Why?

- Acquisition of experience with in-water technologies should be a primary goal of international collaboration.
- Development of mechanisms to keep the international community informed about and involved with various planned deployments is important, and, given regulatory

constraints, it may prove more efficient to do certain testing in one jurisdiction as opposed to the other.

- Collaboration on sensor platform design and instrumentation would lead to increases in data quality and efficiencies in data collection.

Successful collaborations tend to grow from the grassroots up, rather than being driven from higher levels. What are the best ways to connect international researchers so that new collaborations in these areas will be generated?

- Regular meetings, ideally at sites of planned deployments.
- Grants targeting international collaboration, even at a small scale. These could include grants to students for participation in international deployments, travel grants for students and faculty to stimulate collaboration, and/or seed grants to explore a new research area with international implications, in addition to large-scale grants for the development of international research programs.
- Another effective mode of collaboration would be to increase the efficiency of data sharing, through web-sites or other mechanisms.

International collaborations often require separate funding sources from each jurisdiction. What are the best strategies for funding these international collaborations? What other programs or tools might be useful for facilitating these efforts? How might these be created / initiated?

- Other marine resource sectors, for example oil and gas, may be interested in collaboration, thus leveraging marine renewable funds.
- Some specification for international collaboration in requests for proposals could be a useful, top-down mechanism for fostering collaborations.
- Dreaming small may be a good idea initially. Crisp focus on a shared problem of manageable scale could lead to modest contributions from two or more funding agencies. Success at this scale could lead to broader ambitions and greater resources. Interaction of blades and biology was given as an example.

Group 2 – Research Collaboration across Tidal Sites in Nova Scotia (Minas Passage, Digby Neck, Cape Breton)

Group Lead: Alex Hay, Dalhousie University

The keys points resulting from the group discussion are as follows:

What research topics should be the first priorities for cross site collaborative efforts? Why?

- Effects on marine mammals and fish
 - Pick species present at both (Minas & Digby) sites (e.g. harbour porpoise)
 - Understand how species use the channels for migration
 - Determine how to monitor fish behaviour around structures

- Site assessment methodologies
- Hydrodynamics

What are the benefits of inter-site collaboration?

- Advantages of low flow sites for testing
 - Lower risk
 - Easier access (non-drying harbours)
 - Divers can be used
 - Bridge infrastructure available (Cape Breton)
- Sharing instrumentation and data tools
- Cross-validation of methods with high flow site
- Access to funding (collaborative teams)
- Range of conditions (turbid/clear; up to 5 m/s speeds)

What are the obstacles?

- IP issues when collaborating
- Approval for government scientist involvement
- Funding: encourage cross-site collaboration in proposals
- Access to vessels

What needs to be done to facilitate and sustain such collaborative studies?

- Working groups on particular topics (i.e. fish detection, ambient noise measurement, turbulence, etc. for high flow environments)
- Identify incentives for industry involvement
 - Improvements to instruments
 - Raise company profile in tidal energy community
 - Learning opportunity

Group 3 – Regional Multi-Sector Collaboration (Academic, Government, Industry)

Group Lead: Elisa Obermann, Marine Renewables Canada & FORCE

The keys points resulting from the group discussion are as follows:

What specific research projects could be best accomplished through multi-sector collaboration? Why?

The overarching theme in regards to this question was that many projects require multiple disciplines and sectors (biology, geology, oceanography, vessels, ocean tech, etc.) in order to deliver a successful product and results.

Group participants provided suggestions on several projects that could be accomplished through multi-sector collaboration:

- Compile information about site conditions (requires participation from all and scope includes all relevant disciplines).

- Substructure for multiple turbines: reduce the cost and risk of deployment, operation & maintenance.
- Development of technologies to facilitate the required research (sensors, instrumentation for high-flow).

What are the barriers to cross-sector research collaboration?

Group participants stated that the following issues were barriers to cross-sector collaboration:

- a. Funding
 - There is currently competition for funding among many groups including private and public/academic entities. In some cases the private sector is not always included in funding calls or opportunities despite the fact that they already have expertise and knowledge in these areas. This can create duplication and inefficiency.
 - Due to the state and maturity of the sector (no large commercial project/industry players) it may be difficult for funders to understand the future and potential opportunities.
- b. Federal government policy
 - There is a lack of government support for science/ocean-related research at the federal level. Research budgets have been cut and some of the solid expertise and knowledge that once existed in government is diminishing.
- c. Leadership (no central oversight/coordination)
 - Canada lacks a central institution / organization that links industry, academia and government together. This has resulted in no central oversight or overarching national strategy for marine renewable energy.
- d. Need to think bigger: focus on scale of activity required and not just smaller projects here and there that collectively may not achieve the end goal.

What needs to be done to facilitate and sustain such collaborative projects?

- Participants felt that one of the major needs is central leadership and some type of umbrella organization that would interface with governments and stakeholders.
- A central repository for data/research (federal government? new entity?) would also help to ensure that all parties have common knowledge and access to information.
- Resources that currently exist should be leveraged (domestic/international funding, human resources, etc.).
- It was also pointed out that setting targets and milestones would be beneficial, achieving accountability and providing a framework/plan for moving forward (who, what, when, etc.).

- A collective effort to access existing programs/funding is required (Network of Centres of Excellence [BL-NCE, CECR], NSERC, OERA).
- Ongoing communication and engagement among sectors is crucial to facilitate ongoing collaboration. This can be accomplished through networks such as FERN.
- Demonstration of public interest/benefits (cost-benefit analysis, social license).

Group 4 – Involvement of Community Stakeholders, Policy Makers and Regulators

Group Lead: John Colton, Acadia University

Developing communication and partnerships between researchers and different stakeholder groups can have many benefits including identifying priorities and needs, building social license and political/funding support, informing appropriate regulation & policy making, and informing development permitting and regulatory decisions.

The keys points resulting from the group discussion are as follows:

What have been the most significant challenges of building communication and partnerships between researchers and different stakeholder groups (community, regulators, policy makers)?

- Developing meaningful dialogue between all partners
- Developing trust among partners
 - Trust needs to be earned
- Avoid making grand announcements and making big promises
- Establishing realistic community expectations around socio-economic benefits
- Poor communication strategies
- Challenge to maintain ongoing consultations
- There is a lot of research but it is not always clear how it will be used
- Building partnerships requires a delicate balance of proper investment, communication, and feedback to all partners
- Stakeholders need to be treated the same
- One failure (e.g. turbine failure) requires time and resources to rebuild public confidence
- It is often hard to communicate with government policy makers
- Developers and government often do not recognize the need for proper engagement
- Adequate funds are not set aside in most cases for sufficient community engagement

What types of processes or tools have worked and/or should be developed to connect researchers with regulators and other stakeholder to help generate research projects that address the priorities and needs of these stakeholder groups?

- Providing fishery reports to fishing community
- Bringing stakeholders together through:
 - Open houses

- Community meetings
 - Meet and greet the scientists
- Build trust
- Cooperative research (involving community)
- Stakeholders have to have a stake in order to engage
- Provide the appropriate types of engagement (involve, consult)
- Need right people to lead engagement
- Allocate budgets for communication
- Work to involve local community
 - Students
 - Hire local people
 - Use local assets for research

What process, methods or tools would best support meaningful dissemination and appreciation of the outcomes of research to different stakeholder groups?

- Share successes in other industries
 - Solid waste management system good example (Nova Scotia)
- Communication strategy
 - No when and when not to communicate to stakeholder groups
- Develop networking events to share and disseminate research
- Develop appropriate maps and other displays of research and research areas. Examples might include maps of tidal resources in province.
- If possible, share research outcomes on local TV cable networks and other media like radio and community Facebook pages
- Provide seminars to stakeholders
- Attend and present research outcomes at monthly meetings of fishing and other relevant associations
- Attend and share research government forums
- Develop opportunities to work with schools
- Develop public displays re: development of tidal (portable)
- Consider location of visitor facilities (i.e., how close to visitor markets)
- Hold Open Houses and promote these widely
- Involve media people in research trips
- Use relevant websites (e.g. Saving Seafood website...#1 media transit for fishing issues) to share research
- Good example of cooperation and sharing of research: fisherman/Scientist Research Society
 - Joint research projects

Group 5 – Coordination of Roles and Responsibilities among Groups and Institutions

Group Lead: Carey Ryan, OERA & Thackeray Consulting

Many institutions are working to advance tidal energy research in Nova Scotia. These include: MRC, FORCE, Fundy Tidal Inc., OERA, Halifax Marine Research Institute, ATEI, FERN, NS Department of Energy, DFO, Natural Resources Canada, among others. The roles and responsibilities of each group are often complex and interconnected. This creates the perception of duplication and lack of coordination amongst the various entities.

The keys points resulting from the group discussion are as follows:

In your experience, what are the most significant benefits and challenges to the complex organizational landscape in NS? Canada?

Benefits of having a variety of organizations involved in some way in tidal energy R&D were identified as:

- There is a diversity of views, expertise and skills resulting in a variety of perspectives and capabilities to identify opportunities and threats related to tidal energy development and undertake R&D address the challenges.
- In spite of the apparent large number of organizations, the number of individuals involved is relatively small. They know each other and their respective skills and capabilities. This fosters good communication and leads to the development of collaborative research programs that can tap into a variety of funding sources.
- Research clusters have emerged in particular areas related to tidal energy (e.g. site characterization, resource assessment, environmental impacts) and the expertise is recognized internationally. This has helped to open the door to international collaborations. One of the benefits of such collaborations has been the transfer of knowledge to local researchers from those in other jurisdictions.
- Individual organizations understand their own mandates as well as those of the other organizations, and they have developed good working relationships amongst themselves. The complexity is more the perception of those looking in from the outside rather than those directly involved in tidal energy R&D.

The challenges identified were:

- Although there are linkages between the organizations there is no lead organization to facilitate and coordinate activities.
- Different organizations have different, although to some extent overlapping, areas of interest and focus making it more difficult to develop a consensus on R&D needs, goals and a strategy for moving forward.
- While the relatively small and tightly knit tidal research community in Nova Scotia is seen as a benefit, in other respects it acts as a challenge in the sense that thinking becomes more insular.

- Because Nova Scotia is a small province and the organizations are for the most part provincial and relatively small, it makes it more difficult to gain traction with international organizations that have the backing of national governments. This could impact access to or involvement in international efforts.
- Although there are an apparent large number of organizations involved provincially in tidal energy, they lack industry involvement. In addition some felt there is a tendency for discussion and inter-organizational communications to overshadow action.
- There is no directory of organizations involved in various aspects of tidal energy to provide external parties with an understanding of their mandates, roles, responsibilities, interrelationships and activities undertaken.
- There is the potential for competition for funding between the organizations rather than a coordinated approach.

What, if anything, needs to be done to clarify, coordinate or interconnect the roles and responsibilities? Why? How can these actions be achieved?

The points raised were:

- Although the list of organizations appears to be relatively large, the degree of overlap is not that great once they are sorted into categories based on their primary roles and responsibilities – research providers, research users or beneficiaries, research funders, regulators and facilitators. In some instances an organization may play more than one role.
- If Nova Scotia is going to achieve its vision for tidal power by 2020 there needs to be a mechanism in place to move forward with the top 2 or 3 priority research programs and to complete them. In addition, there needs to be an increase in industry driven research to address key technical challenges. It was also recognized that Nova Scotia needs to capitalize on international research efforts and to do so has to strengthen its ties and become formally involved in collaborative international research programs.
- There is a need for one organization that is recognized by the others as playing a strategic role in working with the others to establish the needs and priorities for tidal energy R&D; and as having the responsibility for driving priority research programs forward. Ideally the organization should be seen as neutral, have strong program management skills, have access to R&D monies, have the ability to access or leverage other funding sources and be results oriented.
- OERA was identified as an organization that fits that description although it was noted that it is perceived as being primarily a research organization that stops short of development or pre-commercialization activities, and is lacking industry involvement. There needs to be as much attention to the issues that impact the commercial viability of tidal as there is to the environmental, siting and socio-economic R&D components.
- Another suggestion was some type of structure jointly chaired by OERA and MRC to take advantage of MRC's industry involvement. This might be a working group with representation from industry, communities, NGOs, the R&D community and provincial and federal governments. The counter argument to this approach is that there are already

a large number of organizations involved in tidal energy and the need for another is questionable.

- The final point is the need for a “clearinghouse” for information and data related to tidal energy. Without it there is a risk of efforts being duplicated and full advantage not being taken of past work or work conducted in other parts of the world.

Group 6 – Engagement and Collaboration with Students in Tidal Energy Research in NS

Group Leads: Justine McMillan, Dalhousie University & Monica Reed, Acadia University

The keys points resulting from the group discussion are as follows:

How can students contribute to the advancement of tidal energy research in Nova Scotia?

- Data analysis
- Field work
- Report writing
- Encourage collaboration between academia and industry, between academia and communities
- Community outreach
- Improvement of online resources

Is there a practical program that could be put in place to aid students?

- Small subprojects that cater to student timelines and with data that can be published.
- Companies funding research have to facilitate student engagement. They have to create the roles for students and have grants available to make student collaboration feasible.

What opportunities for collaboration can students benefit from? How can these benefits be attained? Are there any opportunities available to students that seem to be underutilized? Why do you think this is so?

- General lack of knowledge about available opportunities; indicates more effective communication is needed
- Multi-institutional (academic and industry) collaborations: Industry needs to communicate with researchers as to what needs to be done/ what students can do
- Access to information: OERA, DFO and other websites are often out of date or do not always have reports available for download
- UK MCT/Seagen doctoral training program
- NSERC Industrial grants: relatively well known
- OERA has travel grants: not well known among students
- International Network in Ocean Renewable Energy (INORE) (network for students and young professionals): not well utilized by NS students.
 - Holds symposiums/workshops for students and young researchers in ocean renewable energy: will be one associated with ICOE 2014 in Halifax
 - INORE also gives International Collaborative Incentive Scholarshipsto INORE members for site visits etc., which are underused

What are the roadblocks associated with student engagement in collaborative projects? How can they be mitigated?

- Lack of summarized information (organizations, funding sources, programs)
- Timelines
 - Tidal energy development is moving too slowly given the short duration students have for research projects (i.e. 1-3 years)
 - Need supervisors establishing collaborations beforehand; students can be given Graduate degree size components of a larger project
 - Should direct funding towards groups that have collaborative networks already in place, so student doesn't have to initiate these collaborations
- Funding schedules need to line up with field schedules
 - Funding approval needs to align with field research/ student timelines
 - Funding agencies need to understand the restrictions on student availability to work on projects since students have academic program responsibilities other than research
- Data has to be publishable: may be an issue if working with industry
- Steep learning curves
- Grants for students need to be increased / maintained (e.g. NSERC)
- Multi-institutional/lab collaboration may be difficult if there is competition

What tools, programs or projects would facilitate successful collaborations both locally and internationally?

- Online database and forum for NS students. Some participants thought a new regional student-specific forum should be developed, while others thought a new institute unnecessary as FERN could be built upon to address students' needs. The creation of a new forum would require personnel and funding. The idea to create a student co-op position to establish and maintain the forum was put forth. The following were suggested components of the database and forum:
 - Overview of tidal energy research in NS, what has been done thus far and what is planned (FERN has this but more detail would be useful, particularly on future plans)
 - Capacity to facilitate data sharing (FERN has, just needs to be utilized more)
 - Documents (reports, papers) relevant to tidal energy available for download (FERN's library has documents available to download, and provides the opportunity to contribute your work to the collection)
 - List of organizations and researchers involved in tidal energy and what they are doing (FERN has links to organizations' websites but no information on activities of each, info on current projects but no specifics about researchers)
 - Funding information
 - News and upcoming events (FERN has but could include more student-specific items)
- The Acadia Tidal Energy Student Association (ATESA) was discussed. It is a student run club initiated in 2012 at Acadia University. The responsibility of establishing and maintaining a regional student forum is problematic, as students will have limited time available to devote to the forum and there would be a high turnover of executives and members due to graduation and schedule changes each year. ATESA could be used and/or expanded to enhance regional collaboration and opportunities for students

associated with tidal energy research to meet and discuss their current projects, issues and plans.

- INORE was also discussed. INORE could be utilized to build international connections, share information about international events (conferences, workshops etc.) relating to marine renewable energy, and to gain insight into the activities and developments of all marine renewable energy fields.

<p style="text-align: center;">DAY 2 BREAKOUT SESSION THEME</p> <p style="text-align: center;">SOLUTIONS TO RESEARCH CHALLENGES</p>

The purpose of this session was to provide delegates with an opportunity to start discussing practical solutions to current key hurdles to advancing Research & Development of in-stream tidal energy development in Nova Scotia.

Symposium delegates were assigned to one of five discussion groups on the following topics:

1. Technical Challenges to Environmental Sensing and Monitoring in High Flow Environments
2. Turbine and Infrastructure Engineering, Operation and Maintenance Challenges in High Flow Sites
3. Environmental Research and Monitoring to Minimize Risk and Uncertainty: a) cumulative and scale-specific environmental effects and b) activities beyond the scope of regulatory requirements
4. Determining the Potential Social and Economic Outlook of In-Stream Tidal Energy in Nova Scotia
5. Access to Existing Technical Data & Information Sharing Among Teams, Institutions and Sectors

Specifically, each group was asked to:

1. Develop a realistic strategy or plan to overcome this challenge. Include:
 - a. What are the barriers that need to be overcome?
 - b. What are the existing opportunities?
 - c. Who should be involved and what would be their responsibilities?
 - d. What resources are needed (funding, expertise, instruments, facilities etc.) and where/how might they be obtained?
2. Outline the major steps in the plan and possible timeline
3. Recommend 1 or 2 practical Action Items that could be conducted in the next 3 to 6 months.

An effort was made to match delegate expertise to the topics, but also to provide an even balance of institutional and sectoral representation across groups.

The following are the key points resulting from the discussions.

Group 1 - Technical Challenges to Environmental Sensing and Monitoring in High Flow Environments

Group Lead: Simon Melrose, Oceans Ltd.

The discussion focused on the need to put more effort into talking about the issues, the problems and the potential solutions to monitoring in high flow environments like the Minas Passage. The potential solutions could include activities related to vessel operations, instrument fabrication and research.

1. There are a number of barriers that need to be overcome but the leading issues are the availability of vessels (first) and instrumentation (second) able to work effectively in high flow environments. We need to prove and select technologies that we are able to get in and out of the water and understand the results.
2. These are challenges for both the science and the business communities.
3. The resources required include projects, personnel and a business case for funding.

The specific review of the research challenges clearly identified four major recommendations:

1. The target timeline for the demonstration of real progress in instruments, methodologies and understanding of the site must be set to stay within a 2 year window to meet developers' expectations.
2. Every effort should be made to develop a program to migrate testing and development from a moderate test area/regime to the harsher environment of the Minas Passage.
3. The FORCE sensor platform would provide a significant opportunity if it is available within the target timelines.
4. There is a clear need for a Social Licence that will link the business case to the environmental monitoring and effects programs. Community / stakeholder engagement (business, education, science and general public) is needed to both demonstrate the efforts underway and generate positive support for the science and the business opportunities.

Group 2 - Turbine and Infrastructure Engineering, Operation and Maintenance Challenges in High Flow Sites

Group Lead: Sue Molloy, Glas Ocean Engineering

What are the barriers that need to be overcome?

- On-water operations and mobilization of vessels to locations such as those in the Bay of Fundy have a significant impact on the overall capital and maintenance costs. Minimizing on-water operations would have a dramatic impact on the operations and maintenance costs in the short term.
- Consider options such as utilizing Black Rock as an anchor point (Minas Passage) for operations, direct drilling of cables, or using bridges or marine railways.
- There are concerns about turbine-induced liquefaction of mud expected to be under the gravel in the FORCE site.

What are the existing opportunities?

- Scaling versus commercial deployment. Given that no one has had success in the Bay of Fundy as of yet, a nursery or small scale site may be valuable to help inform installations at FORCE. Perhaps some initial focus and support on a COMFIT site would achieve this.
- Core sampling and turbine vibration studies would help answer the liquefaction concerns.

Who should be involved and what would be their responsibilities?

- There is a large Shale gas industry in Atlantic Canada and a long history of Oil and Gas. Inviting the experts from these industries and the subsea engineering groups in Atlantic Canada to help solve the issues would be a very strong step forward.
- NS Power has laid an electrical cable in Grand Passage and their expertise should be engaged on the FORCE and other tidal power cable laying if it has not already.

What resources are needed and where might they be obtained?

- Financial resources to run studies and support developers.
- Cost of core sampling could be reduced through collaboration of all berth holders from FORCE and Bay of Fundy COMFIT sites, which would significantly reduce mobilization costs.
- Universities could be used to assist in the study of vibrations, installation and deployment systems, and further site characterization.

Action items that could be achieved in the next few months.

- The FORCE governance structure, with a decision-making board consisting of organizations with competing public (provincial government) and private interests (different berth holders), may not be creating enough incentive for efficient use of financial resources. Separating operational decisions at FORCE from the board interests may address this concern.

- An engineering task force comprised of technical experts (e.g. operators, construction specialists, academic engineers) that specifically advise on the engineering challenges of the FORCE and COMFIT projects. This committee would be similar to the science advisory group of experts that has been assembled for the sensor platform project at FORCE.
- A method for sharing and disseminating information on the FORCE and COMFIT sites so that the site characterization work can continually be built on even if a berth holder moves on.

Group 3 - Environmental Research and Monitoring to Minimize Risk and Uncertainty: a) cumulative and scale-specific environmental effects and b) activities beyond the scope of regulatory requirements

Group Lead: Kristian Curran, Fisheries and Oceans Canada

What are the barriers that need to be overcome?

- Data availability
- Technological barriers (e.g. fish mortality - herring)
- Long-term funding and planning
- Who carries out long-term monitoring outside of Proponent obligations?
- Communication with Industry and Government – industry and government define acceptable risk
- Government and Industry must help peer review and validate monitoring elements and protocols
- Scope (monitoring tidal developments vs. monitoring high-flow environments) – the latter may have application to other industries

What are the existing opportunities?

- Learnings from other industries (e.g. petroleum industry)
- Community of experts to draw upon
- Research organizations and expert groups exist
- Government support for R&D of technologies that could be used for monitoring. Given governments current emphasis on technology development, this presents an existing opportunity to make a case for support for tidal technologies development
- Connections with other tidal development areas (e.g. MOUs, etc.)
- Strategic Environmental Assessments (Bay of Fundy and Cape Breton) can help identify research and monitoring priorities

Who should be involved and what would be their responsibilities?

- Government: legislative/regulatory & compliance monitoring
- Industry: near-field effects
- Academics: define and develop methods and protocols for monitoring – facilitate long-term, broad-scale monitoring
- Communities: defining and participating in monitoring (empowerment in process)

What resources are needed (funding, expertise, instruments, facilities, etc.) and where/how might they be obtained?

- Turbine to work with
- Vessels
- Other potential development sites for arrays. For example, other sites where future commercial developments may be placed beyond the Minas Passage and Digby area (e.g. central Bay of Fundy?)
- Develop novel monitoring instruments (economies of scale)
- More support for environmental studies, including support staff (there has been money for equipment, but not for people to do the work)
- Leverage with other sectors to pursue opportunities of mutual interest (e.g. LiDAR collected for Climate Change can be applied to tidal)

Major steps in the plan

1. Work towards identifying monitoring elements, protocols and standards – risk and gap analysis
2. Identify roles and responsibilities (legislated vs. social, as well as among stakeholders)
3. Get turbines in water
4. Re-focus on lower energy projects and scale up?
5. Current governance model working well (i.e. OERA, FERN and FORCE) – next step to build international relationships
6. Identify practical barriers (e.g. limitations on ability to travel to conferences)

Recommendations

1. Build upon community engagement to assist with baseline monitoring
2. Identify legislated vs. social monitoring requirements and identify roles and responsibilities (in consideration of recent changes to federal environmental legislation)
3. Have monitoring protocols peer reviewed
4. Make use of virtual forums (e.g. WebEx, web-portals, etc.)
5. Collaboration with other existing research programs and funds (e.g. climate change)
6. Develop a long-term research and monitoring plan (central group to oversee this)

Group 4 - Determining the Potential Social and Economic Outlook of In-Stream Tidal Energy in Nova Scotia

Group Lead: Kay Crinean, Maritime Tidal Energy Corp.

Major Steps in the plan

1. Overcoming unknowns
 - Need to identify what work has been done already and focus on what is known.
 - Don't raise unrealistic expectations – it will take time to develop the industry and get relevant data.
2. Communicating supply chain opportunities
 - Need for tidal industry representatives to be engaged in local industry events over the long term to build relationships.
 - Marine Renewables Canada (MRC) released a report that indicates the types of expertise that will be required at different stages of product/industry development (Business

Opportunities from Marine Renewable Energy Development and Project Lifecycle Needs, 2012 [*available on the MRC website*]). Need to work with industry associations so awareness about these needs can be raised and communicated.

- Need to take lessons from other industries. Many of the services and issues are common with offshore oil and gas industries e.g. asset integrity (corrosion etc.), cable-laying, deployment issues, project management and risk management planning.

3. Long term view needed

- Export opportunities need to be identified and monitored.
- Tidal (local) will be a sub-set of companies' overall work; therefore, we need to encourage companies with existing expertise to get involved.
- If we wait too long, expertise will be sourced from elsewhere. Fine balance.
- Communication is required to help companies identify local and global opportunities; build relationships.

4. R&D

- Do a series of case studies of companies that seized opportunities in offshore oil and gas, and those that didn't succeed. Lessons learned.
- Site characterization, resource assessment opportunities – we have expertise, and South America is starting to express needs.
- Identify expertise that we already have and export that.

Recommendations / Priorities

- Communicate strategy to supply chain - MRC and NS Department of Energy need to address; some work being done.
- Need to draw on and build up expertise in NS in order to export – e.g. the FORCE sensor project; site characterization; resource assessment.
- Challenges in Minas Passage are slowing progress (FORCE site = Everest): we should also focus on the small scale projects – easier to invest and get experience; there is a global market.
- Use FORCE as a test site for arrays and an operational site for early, small commercial arrays), not a test site for single turbines.
- Scenario planning – several scenarios to provide a basis for assessing social and economic outlook. What might the industry look like in future, internationally and locally, and what actions need to be taken now to enable them to take place?
- Strategic filters or questions to ask along the way to determine next steps.
- Identify and communicate progress made towards vision and goals for industry.

Group 5 - Access to Existing Technical Data & Information Sharing Among Teams, Institutions and Sectors

Group Lead: Richard Karsten, Acadia University

What are the barriers that need to be overcome?

- Establish data sharing between groups, even between government departments / groups (internal access issues).
- Access to raw data.

- Lack of comprehensive data and report inventories. There are few accessible inventories of the datasets that have been collected – not making use of what data already exists.
- Legacy data, who manages it? Dependent on whether the data are collected by independent researchers or for government projects.

What are the existing opportunities?

- Data are currently being shared, but usual only within research groups and on a small scale. These efforts could be built on.
- Small scale digital libraries (data, reports).
- There are existing data repositories – Ocean Network Canada, Ocean Tracking Network’s Platform for Ocean Knowledge Management (POKM) – for similar types of data. These could be used/adapted/copied for tidal energy.

Who should be involved and what would be their responsibilities?

- Universities, government researchers, industry, umbrella organizations, etc. All groups can be involved in data sharing, but it may require an umbrella group (OERA, FERN, MRC) to establish a large data repository.

What resources are needed (funding, expertise, instruments, facilities etc.) and where/how might they be obtained?

- User-friendly, accessible digital data environment.
- Standardized datasets.
- Group/organization to spearhead this initiative.

Major steps in the plan

- Annual workshops. Informal workshops (government, universities, tidal power developers) to get everyone up to speed and to establish connections and collaborative relationships – lets everyone know what types of datasets are available and who is doing what.
- Create a central data repository and digital library for all Bay of Fundy datasets and reports/summaries, accessible to all. Establishing links between private groups conducting research and academia. This also ensures data are in a standardized format.
- Digitizing older reports.

Recommendations

- Make information public.
- OERA or FORCE need to issue a call for data management proposals and data archiving systems?

8.0 List of Symposium Delegates

Name	Affiliation
Aaron MacNeill	Dalhousie University
Adrian Woodroffe	OceanWorks International
Alain Joseph	Nova Scotia Community College
Alan Howell	NS Department of Energy
Alex Hay	Dalhousie University
Allyn Clarke	Fisheries and Oceans Canada
Amanda Babin	University of New Brunswick
Anna Redden	Acadia University
Brent Law	Fisheries and Oceans Canada
Brian Sanderson	Acadia Centre for Estuarine Research
Brian Todd	Geological Survey of Canada (Atlantic)
Bruce Cameron	NS Department of Energy
Bruce Cameron	Nextwave Ocean Energy Ltd.
Bruce Martin	Jasco Applied Sciences
Carey Ryan	Offshore Energy Research Association
CarolAnne Black	Dalhousie University
Chloe Malinka	Dalhousie University
Chris Peters	Minas Basin Pulp & Power
Chris White	Dalhousie University
Craig Brown	McGregor Geosciences
Dana Morin	Fundy Tidal Inc.
Daniel G. MacDonald	University of Massachusetts Dartmouth
Danika van Proosdij	Saint Mary's University
David Greenberg	Fisheries and Oceans Canada
David Lombardi	Seaforth Geosurveys
David Schlezinger	University of Massachusetts Dartmouth
Dean Steinke	Dynamic Systems Analysis Ltd.
Donald Gordon	Fisheries and Oceans Canada
Donald Humphrey	Fisheries and Oceans Canada
Doug Keefe	Fundy Ocean Research Centre for Energy
Elisa Obermann	Marine Renewables Canada
Emma Poirier	Saint Mary's University
Freya Keyser	Acadia University
Geoff Keith	Synapse
Gordon Fader	Atlantic Marine Geological Consulting Ltd
Graham Daborn	Acadia University
Greg Decker	NS Department of Energy
Greg Trowse	Dalhousie University
Heather Levy	Envirosphere Consultants
Isabel Madeira-Voss	Nova Scotia Community College
Jamie Ross	Nightsail Marine Energy Research
Jason Wood	Sea Mammal Research Unit Ltd.

Name	Affiliation
Jennifer Pinks	Offshore Energy Research Association
Jeremy Broome	Acadia University
Jessica Carrière-Garwood	Dalhousie University
Jing Tao	Dalhousie University
Jocelyn Fraser	NS Utility and Review Board
Joe Kozak	Fundy Ocean Research Centre for Energy
Joel Culina	Oceans Ltd.
John Colton	Acadia University
John Shaw	Geological Survey of Canada (Atlantic)
Jon Mackie	Seaforth Geosurveys
Josh Leon	Dalhousie University
Justine McMillan	Dalhousie University
Kay Crinean	Maritime Tidal Energy Corp.
Kaycee Morrison	Acadia University
Kevin Stokesbury	University of Massachusetts Dartmouth
Kristian Curran	Fisheries and Oceans Canada
Krystal Nowe	Acadia University
Leanda Delaney	Fisheries and Oceans Canada
Lisa Isaacman	Fundy Energy Research Network
Lisa Visentin	Acadia University
Mark Wood	Ocean Sonics Ltd.
Matthew Baker	Acadia University
Melanie MacLean	Fisheries and Oceans Canada
Melissa Oldreive	NS Department of Energy
Michael Brylinsky	Acadia University
Mitchell O'Flaherty-Sproul	Acadia University
Monica Reed	Acadia University
Montana McLean	Acadia University
Murray Coolican	NS Department of Energy
Murray Scotney	ROMOR Ocean Solutions
Nat Pearre	Dalhousie University
Nina Stark	Dalhousie University
Norman Cochrane	Fisheries and Oceans Canada
Patrick Stewart	Envirosphere Consultants
Paul Hill	Dalhousie University
Peter Porskamp	Acadia University
Richard Cheel	Dalhousie University
Richard Isnor	Natural Sciences and Engineering Research Council
Richard Karsten	Acadia University
Robert Miller	Fisheries and Oceans Canada
Rod Bradford	Fisheries and Oceans Canada
Roland Samimy	University of Massachusetts Dartmouth
Ron Scott	Maritime Tidal Energy Corp.
Russell Dmytriw	AECOM

Name	Affiliation
Sandra Farwell	NS Department of Energy
Scott McLean	Ocean Network Canada Centre for Enterprise & Engagement
Sheila Paterson	NS Department of Energy
Shelley MacDougall	Acadia University
Simon Melrose	Oceans Ltd.
Stephen Dempsey	Offshore Energy Research Association
Steve Sanford	NS Department of Environment
Sue Molloy	Glas Ocean Engineering
Toby Balch	NS Department of Energy
Tom Herman	Acadia University
Tony Wright	Fundy Ocean Research Centre for Energy
Trevor Avery	Acadia University